

fax



**EDDIE BAZA CALVO**  
Governor

**RAY TENORIO**  
Lieutenant Governor

*Office of the Governor of Guam*

June 18, 2012

Honorable Judith T. Won Pat, Ed.D.  
Speaker  
*I Mina'trentai Unu Na Liheslaturan Guåhan*  
155 Hesler Street  
Hagåtña, Guam 96910

31-12-1015  
Office of the Speaker  
**Judith T. Won Pat, Ed. D.**

Date 6/19/12  
Time 4:37 PM  
Received by [Signature]

Dear Madame Speaker:

Transmitted herewith is Bill No. 458-31 (COR) "AN ACT TO REPEAL AND RE-ENACT SECTION 4 OF PUBLIC LAW 31-209, RELATIVE TO THE TRANSFER OF PARCELS IN THE SAGAN LINAHYAN SUBDIVISION, DEDEDO GUAM", which I signed into law on June 12, 2012 as **Public Law 31-215**.

*Senseramente,*

  
**RAY TENORIO**  
*I Maga'lahaen Guåhan para pa'go*  
Acting Governor of Guam

2012 JUN 19 PM 5:03  

Attachment: copy of Bill

1615

**I MINA'TRENTAI UNU NA LIHESLATURAN GUÅHAN**  
**2012 (SECOND) Regular Session**

**CERTIFICATION OF PASSAGE OF AN ACT TO I MAGA'LAHEN GUÅHAN**

This is to certify that **Bill No. 458-31 (COR)**, "AN ACT TO REPEAL AND RE-ENACT SECTION 4 OF PUBLIC LAW 31-209, RELATIVE TO THE TRANSFER OF PARCELS IN THE SAGAN LINAHYAN SUBDIVISION, DEDEDO, GUAM", was on the 4<sup>th</sup> day of June, 2012, duly and regularly passed.



\_\_\_\_\_  
**Judith T. Won Pat, Ed.D.**  
Speaker

Attested:



\_\_\_\_\_  
**Tina Rose Muña Barnes**  
Legislative Secretary

-----

This Act was received by *I Maga'lahaen Guåhan* this 7<sup>th</sup> day of June, 2012, at 1:10 o'clock P.M.

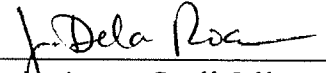

\_\_\_\_\_  
Assistant Staff Officer  
*Maga'laha*'s Office

APPROVED:



\_\_\_\_\_  
**RAYMOND S. TENORIO**  
Acting Governor of Guam

Date:

June 12, 2012

Public Law No. 31-215

***I MINA'TRENTAI UNU NA LIHESLATURAN GUÅHAN***  
**2012 (SECOND) Regular Session**

**Bill No. 458-31 (COR)**

Introduced by:

T. R Muña Barnes  
T. C. Ada  
V. Anthony Ada  
F. F. Blas, Jr.  
B. J.F. Cruz  
Chris M. Dueñas  
Judith P. Guthertz, DPA  
Sam Mabini, Ph.D.  
Adolpho B. Palacios, Sr.  
V. C. Pangelinan  
Dennis G. Rodriguez, Jr.  
R. J. Respicio  
M. Silva Taijeron  
Aline A.Yamashita, Ph.D.  
Judith T. Won Pat, Ed.D.

**AN ACT TO REPEAL AND RE-ENACT SECTION 4 OF  
PUBLIC LAW 31-209, RELATIVE TO THE TRANSFER  
OF PARCELS IN THE SAGAN LINAHYAN  
SUBDIVISION, DEDEDO, GUAM.**

1           **BE IT ENACTED BY THE PEOPLE OF GUAM:**

2           **Section 1.** Section 4 of Public Law 31-209 is hereby *repealed* and *re-*  
3 *enacted* to read:

4                   **“Section 4. Effective Date.** This Act *shall* be effective upon  
5 enactment into law.”

6

# I MINA' TRENTAI UNU NA LIHESLATURAN GUÅHAN

2012 (SECOND) Regular Session

Date: 6/4/12

## VOTING SHEET

Bill No. 458-31(COR)

Resolution No. \_\_\_\_\_

Question: \_\_\_\_\_

<u>NAME</u>	<u>YEAS</u>	<u>NAYS</u>	<u>NOT VOTING/ ABSTAINED</u>	<u>OUT DURING ROLL CALL</u>	<u>ABSENT</u>
ADA, Thomas C.	✓				
ADA, V. Anthony	✓				
BLAS, Frank F., Jr.	✓				
CRUZ, Benjamin J. F.	✓				
DUENAS, Christopher M.	✓				
GUTHERTZ, Judith Paulette	✓				
MABINI, Sam	✓				
MUNA-BARNES, Tina Rose	✓				
PALACIOS, Adolpho Borja, Sr.	✓				
PANGELINAN, vicente (ben) cabrera					EA
RESPICIO, Rory J.	✓				
RODRIGUEZ, Dennis G., Jr.	✓				
SILVA TAIJERON, Mana	✓				
WON PAT, Judith T.	✓				
YAMASHITA, Aline A.	✓				

TOTAL

14      0      0      0      1

CERTIFIED TRUE AND CORRECT.

  
Clerk of the Legislature

\* 3 Passes = No vote  
EA = Excused Absence



I Mina'Trentai Unu Na Liheslaturan Guåhan  
Office of The Legislative Secretary  
Tina Rose Muña Barnes

May 31, 2011

**The Honorable Judith T. Won Pat, Ed.D.**  
Speaker  
*I Mina'trentai Unu Na Liheslaturan Guåhan*  
155 Hesler Place  
Hagåtña, Guam 96910

VIA: **The Honorable Rory J. Respicio**  
Chairperson, Committee on Rules

RE: **Committee Report on Bill No. 458-31 (COR)**

Dear Speaker Won Pat:

Transmitted herewith is the Committee Report on **Bill No. 458-31 (COR)** – “An act to repeal and re-enact Section 4 of Public Law 31-209, relative to the transfer of parcels in the Sagan Linahyan Subdivision, Dededo, Guam.”

Committee votes are as follows:

<u>4</u>	TO DO PASS
_____	TO NOT PASS
<u>5</u>	TO REPORT OUT ONLY
_____	TO ABSTAIN
_____	TO PLACE IN INACTIVE FILE

2012 JUN - 1 AM 11:30

*RM*

Sincerely,

  
Tina Rose Muña Barnes  
Senator



I Mina'Trentai Unu Na Liheslaturan Guåhan  
Office of The Legislative Secretary  
Tina Rose Muña Barnes

---

**COMMITTEE  
REPORT  
ON**

**BILL NO. 458-31 (COR)**  
*(Sponsor: Tina Rose Muña Barnes)*

**“AN ACT TO REPEAL AND RE-  
ENACT SECTION 4 OF PUBLIC LAW  
31-209, RELATIVE TO THE  
TRANSFER OF PARCELS IN THE  
SAGAN LINAHYAN SUBDIVISION,  
DEDEDO, GUAM.”**



**I Mina'Trentai Unu Na Liheslaturan Guåhan**  
**Office of The Legislative Secretary**  
**Tina Rose Muña Barnes**

---

May 31, 2011

**MEMORANDUM**

**To:** **All Members**  
Committee on Municipal Affairs, Tourism, Housing and Recreation.

**From:** Senator Tina Rose Muña Barnes   
Committee Chairperson

**Subject:** **Committee Report on Bill No. 458-31 (COR)**

Transmitted herewith for your consideration is the Committee Report on Bill No. 458-31 (COR) - "An act to repeal and re-enact Section 4 of Public Law 31-209, relative to the transfer of parcels in the Sagan Linahyan Subdivision, Dededo, Guam."

This report includes the following:

- Committee Vote Sheet
- Committee Report Digest
- Copy of Bill No. 458-31 (COR)
- Public Hearing Sign-in Sheet
- Copies of Submitted Testimony on Bill No. 458-31 (COR)
- Copy of COR Referral of Bill No. 458-31 (COR)
- Fiscal Note for Bill No. 458-31 (COR)
- Notices of Public Hearing
- Copy of the Public Hearing Agenda

Please take the appropriate action on the attached vote sheet. Your attention to this matter is greatly appreciated. Should you have any questions or concerns, please do not hesitate to contact me.

*Si Yu'os ma'åse'!*

Chairperson, Committee on Municipal Affairs, Tourism, Housing and Recreation  
Vice Chairperson, Committee on Youth, Cultural Affairs, Procurement, General Government Operations and Public Broadcasting  
155 Hesler Place Hagatña, Guam 96910 [Tel: 671-472-3455/6 Fax: 671-472-3400] [www.tinamunabarnes.com](http://www.tinamunabarnes.com)



# I Mina'Trentai Unu Na Liheslaturan Guåhan

Office of The Legislative Secretary

Tina Rose Muña Barnes

## COMMITTEE VOTING SHEET

Bill No. 458-31 (COR) – “An act to repeal and re-enact Section 4 of Public Law 31-209, relative to the transfer of parcels in the Sagan Lintahyan Subdivision, Dededo, Guam.”

	SIGNATURE	TO PASS	TO NOT PASS	TO REPORT OUT ONLY	TO ABSTAIN DUE TO CONFLICT OF INTEREST	TO PLACE IN INACTIVE FILE
LEGISLATIVE SECRETARY TINA ROSE MUÑA BARNES Chairperson		5/31/12 ✓				
SPEAKER JUDITH T. WON PAT, Ed.D. Vice-Chairperson						
VICE SPEAKER BENJAMIN J.F. CRUZ Member		5/31/12				
SENATOR RORY J. RESPICIO Member						
SENATOR THOMAS C. ADA Member				5/31/12 ✓		
SENATOR DENNIS G. RODRIGUEZ, JR. Member						
SENATOR JUDITH P. GUTHERTZ, DPA Member						
SENATOR ADOLPHO B. PALACIOS, SR. Member				5/31/12 ✓		
SENATOR VICENTE C. PANGELINAN Member						
SENATOR FRANK F. BLAS, JR. Minority Member		5/31/12				
SENATOR ALINE A. YAMASHITA, Ph.D. Minority Member				5/31/12 ✓		
SENATOR V. ANTHONY ADA Minority Member				5/31/12 ✓		
SENATOR MANA SILVA TAIJERON Minority Member						
SENATOR CHRISTOPHER M. DUEÑAS Minority Member				5/31/12		





**I Mina'Trentai Unu Na Liheslaturan Guåhan**  
**Office of The Legislative Secretary**  
**Tina Rose Muña Barnes**

---

**COMMITTEE REPORT DIGEST**

**I. OVERVIEW**

**Bill No. 458-31(COR)** was introduced on **May 18, 2012** by **Senator Tina Rose Muña Barnes**, and was subsequently referred by the Committee on Rules to the **Committee on Municipal Affairs, Tourism, Housing and Recreation** on **May 21, 2012**.

The **Committee on Municipal Affairs, Tourism, Housing and Recreation** convened a public hearing on **Bill No. 458-31(COR)** on **Wednesday, May 30, 2012** at **6:00 PM** in *Lihseslatura's* Public Hearing Room.

**Public Notice Requirements**

Public Hearing notices were disseminated via **e-mail** to all Senators and all main media broadcasting outlets on **Monday, May 22, 2012** (5-Day Notice), and again on **Friday, May 25, 2012** (48-Hour Notice).

**Senators Present**

Senator Tina Rose Muña Barnes, Chairperson  
Senator Mana Silva Tajjeron

**II. SUMMARY OF TESTIMONY & DISCUSSION**

The public hearing on **Bill No. 458-31 (COR)** was Called-to-Order at **6:18 PM**.

**Senator Muña Barnes:** We'll move onto the next bill which is **Bill No. 458-31 (COR)**, an act to repeal and reenact section 4 of Public Law 31-209, relative to the transfer of parcels in the Sagan Linahyan Subdivision in Dededo, Guam. Before I give those the opportunity to speak, I would just like to say that original intent of Public Law 31-209 was to transfer the parcels of land in the Dededo Subdivision of Sagan Linahyan from the Department of Land Management to the Guam Housing Corporation. The Guam Housing Corporation along with the collaboration of GHURA were able to secure a funding source to rehabilitate the properties using both the CBDG and the HUD grants. During debate on the floor, the original bill was amended which required the lots in Sagan Linahyan be made available to the CLTC applicants. I want you to know that after the law was passed as amended on the session floor, it was included that based on the amendment put in that the Guam Housing Corporation could be in jeopardy of losing the funding source it originally intended to utilize. If the funding source is lost, then Guam Housing Corporation would lose \$650,000 in grant funds for the 10 units. The CBDG and the HUD grants for affordable housing must be open for use to everyone



# I Mina'Trentai Unu Na Liheslaturan Guåhan

Office of The Legislative Secretary

Tina Rose Muña Barnes

---

and should not be based on gender or race. I want to note that for the record and it was also noted that one unit in the subdivision was intended for use by an NGO. An NGO for those who don't know is a non-governmental organization and that would work to revitalize the neighborhood, much like what is available at a successful development that we have here today which is, the example would be, Ironwoods, by providing services and conducting programs for residents which would provide outreach programs including job search educations and then offering the residents the opportunity to connect with internet and computers. This development is an important step in reaching the estimated goal of the 6,000 additional homes needed by, if I'm not mistaken, the year 2020 because by the year 2030, we would have needed an extra 7,000 homes. I think this is important to have this legislation publically heard so that we can deal with the saving of a grant of up to \$650,000. With that being said, I'm going to ask on record to testify for this bill, I do have Mr. Ray Topasna and Mr. Martin Benavente. Mr. Benavente, if I may, I'm going to go ahead and yield to Mr. Topasna first. State your name for the record, where you're from, who you represent, and you're in support or not in support of the bill.

**Ray Topasna, Executive Director – GHURA:** Thank you Madam Chair, Senator Muna Barnes and Senator Taijeron for giving me the opportunity to speak in support of Bill 458-31. For the record, my name is Ray Topasna and I am the Executive Director of the Guam Housing and Urban Renewal Authority. [reads written testimony]... and as you mentioned earlier Senator, the \$650,000 which is funded through CDBG through HUD is in jeopardy because of section 4, so we need that taken out completely. Thank you.

**Senator Muña Barnes:** Thank you. Mr. Benavente?

**Martin Benavente:** My name is Martin Benavente. I'm the president for Guam Housing Corporation and yes we support this amendment to the public law. Originally when it was Bill 411, we came in support of this bill. Our testimony hasn't changed, we just want to see what puts us in non-compliance with GHURA's rules to receive this money. I just want to state that between Guam Housing's people and GHURA's people, GHURA has put in a lot of money into this project. They've got their architect's, their engineers, their planners, have been working. They put out bids and all these bids the contractors have come in and I think there were 15 contractors that responded. We're right now at the hour where GHURA is ready to award so we can get these projects started and done. We're being promised that this will happen within two months. That has created an awful lot of excitement over Sagan Linahyan. I just want you to know that we appreciate the partnership that we've developed with GHURA because we've been



# I Mina'Trentai Unu Na Liheslaturan Guåhan

Office of The Legislative Secretary

Tina Rose Muña Barnes

---

working with GHURA since day one when this administration walked in. Both GHURA and Guam Housing were with the Governor when he walked Sagan Linahyan. If you ask me where we can best put the money, I will continue to say that Sagan Linahyan is your best shot right now because it needs the help. We could probably place monies elsewhere and we will down the line, but as top priority I think Sagan Linahyan is something that needs to be done and we're hoping that if we remove section 4 that we become eligible again and maybe we can continue again from there. It's important that we do it as fast as we can. That's why I'm on leave but back to work because I know it's important to me also to make sure that this happens. There are a lot of people who we can help. We have people that are victims of fire that we have no place to put. This will provide us with several units that we can hold year round for just victims of disasters and stuff like that. Other than that, we wanted to help start revitalizing Sagan Linahyan. But there are like 60 other lots there that we can grow from. We do plan to qualify people from the Chamorro Land Trust list to start giving them an opportunity to build a home there because everything there is ready. You've got infrastructure, you've got the people that are good people that want us to come in there and help. So I've got people like EPA, the fire department, the mayor's office is working with us, and of course GHURA is working with us to try and get in there and help clean that place up. You know we want to fix their parks. Down the line, we want to find money to do that also. But we have to get started because this thing has been in our focus now for over a year. We did due diligence in working with Land Management in finding the original names that were on the original contracts and telling them that they need to come in and catch up paying. After several months have gone by, the attorney general decided that we would just send them notices and cancel the contracts. These houses, I have packets for all of you, if you see them today, they have been 20 years abandoned and neglected. Giving it back to heirs or as section 4 was asking for, it's just not going to do us any help. What I think we need to do is those people who really want to stay in those houses once we've fixed them, they can be our first renters. Rental is probably an easier way for some of them because there's a lot of people who are not ready for home ownership. We plan to offer them rental of this unit and they don't have to pay taxes for that, they just pay rent. They don't have to pay insurance, they just pay rent. So it saves them a lot of money and maybe that's the way to do it. It's not maybe, it is the way to do it.

**Senator Taijeron:** Well I supported it the first time around, so I'll support it again. You know this has far reaching effects. You fix communities, you provide affordable homes, you help kids in their communities, you fix their parks and you help them in school, you keep them off of drugs and it just has far reaching effects. I think this is a good program and you can continue to have my support. I applaud you and the chairwoman for



# I Mina'Trentai Unu Na Liheslaturan Guåhan

Office of The Legislative Secretary

Tina Rose Muña Barnes

---

spotting this and working quickly to address it so that we don't lose the funding, so thank you.

**Senator Muña Barnes:** Si yu'os ma'ase Senator Taijeron. I just want to thank everybody who has come here this evening to speak in support of both bills, but on this Bill 458, I just want to say with this primary funding source being in jeopardy and being possibly reprogrammed away from this project, I thought that it was very important to amend this law so that we can ensure that this subdivision has the funds needed to rehabilitate and be utilized by every qualified applicant who qualifies within our community to have this renovated or refurbished house. I do hope that, you did say that there was a packet that you would provide for us, and I hope that we will get that packet for the record. I do also want to ask that if you have written testimony, please to help make it easier on the committee, if we could get a copy submitted to us so that we can go ahead and attach it to the package for deliberation. Both bills are on the agenda for this week and we hope to entertain it within the next day or so. I also want to say that while this amendment changes the law, it remains consistent to the pledge of meeting the demand for affordable housing. Of course my commitment to working closely with both agencies on both Guam Housing and GHURA to make sure that when we do it, the bigger picture is to realize what we can do for affordability of our constituents out there within the community. I always that when you provide a better housing perspective and having a roof over our communities heads then you provide for a better quality of life for them, especially for their children, and the educational outreach can be so much more soaring when they know that they have something to come home to and know that the realization is there whether it'd be through this home ownership or that rental that you spoke about. We will hear it this week and I commit to this body right now that it will be heard on this session agenda.

**Ray Topasna:** Can I just add to that? Over the last 16 or 17 months of the Calvo-Tenorio administration, we've developed a number of partnerships. GHURA, together with Guam Housing Corp. We really need the support of your office Senator Barnes. We're going to be able to help a lot of families, hopefully throughout this administration. We've committed some funds to the (inaudible) Housing Development together again with Guam Housing and as well there's five homes down in Talofoto, another five in Merizo of the former teacher staff housing that we will be renovating as well. There's a lot of plans on the table, both the Guam Housing Corporation side and GHURA and it's just a matter of leveraging our resources, partnering with GHC and Land Management and a number of private developers and we're going to help as many people as we can.

---

Chairperson, Committee on Municipal Affairs, Tourism, Housing and Recreation

Vice Chairperson, Committee on Youth, Cultural Affairs, Procurement, General Government Operations and Public Broadcasting  
155 Hesler Place Hagåtña, Guam 96910 [Tel: 671-472-3455/6 Fax: 671-472-3400] [www.tinamunabarnes.com](http://www.tinamunabarnes.com)



# I Mina'Trentai Unu Na Liheslaturan Guåhan

Office of The Legislative Secretary

Tina Rose Muña Barnes

---

**Martin Benavente:** Just one last thing Senator, you know I want to commend you and your staff for the lightning speed that you guys did this at. We notice it and we appreciate the help because we need all the help. You're one of the very serious partners, your committee has been very good to housing.

**Senator Muña Barnes:** I appreciate the support and the appreciation that the staff continues to put in a lot of long hours and a lot hard work to making sure that if we can improve the quality of life for our community then it makes it better for all of us. I think the relationship of making that reality for that dream to come true then we have to just continue to work together and look at the bigger picture. Saina ma'ase, si yu'os unbenidisi for taking the time to be here. With that being said I will call this public hearing to adjournment at 6:35pm.

The public hearing on Bill No. 458-31 (COR) concluded at 6:35 PM.

### III. FINDINGS & RECOMMENDATIONS

The **Committee on Municipal Affairs, Tourism, Housing and Recreation** hereby reports out **Bill No. 458-31 (COR)**, with the recommendation *'To Report Out Only.'*

---

Chairperson, Committee on Municipal Affairs, Tourism, Housing and Recreation

Vice Chairperson, Committee on Youth, Cultural Affairs, Procurement, General Government Operations and Public Broadcasting  
155 Hesler Place Hagåtña, Guam 96910 [Tel: 671-472-3455/6 Fax: 671-472-3400] [www.tinamunabarnes.com](http://www.tinamunabarnes.com)

*MINA' TRENTAI UNU NA LIHESLATURAN GUÅHAN*  
2012 (SECOND) Regular Session

2012 MAY 18 PM 5:18  
*Ecm*

Bill No. 458-31(COR)

Introduced by:

T. R Muña Barnes

---

**AN ACT TO REPEAL AND RE-ENACT SECTION 4 OF PUBLIC LAW 31-209, RELATIVE TO THE TRANSFER OF PARCELS IN THE SAGAN LINAHYAN SUBDIVISION, DEDEDO, GUAM.**

1 **BE IT ENACTED BY THE PEOPLE OF GUAM:**

2 **Section 1.** Section 4 of Public Law 31-209 is hereby *repealed* and re-  
3 *enacted* to read:

4 ~~“Section 4. Transfer of Parcels. Prior to the transfer of parcels~~  
5 ~~within the Sagan Linahyan Subdivision, Dededo, Guam, from the~~  
6 ~~Department of Land Management to the Guam Housing Corporation, the~~  
7 ~~Guam Housing Corporation shall:~~

8 ~~(1) Publish in a newspaper of general circulation, the names~~  
9 ~~of the given individuals who had contractual agreements to~~  
10 ~~purchase the lot and be given the opportunity to fulfill their~~  
11 ~~contractual agreement. Heirs of the persons who were~~  
12 ~~awarded the lots should be allowed to fulfill their contractual~~  
13 ~~agreement if they meet the eligibility requirements. If there~~  
14 ~~is more than one (1) heir, the lot or lots shall be drawn by~~  
15 ~~lottery if not in probate or in a will or by quitclaim of all~~  
16 ~~other heirs.~~

1                   ~~(2) If lots are still available after going through the process~~  
2                   ~~as outlined in (1) above, said lots shall be made available to~~  
3                   ~~the eligible Chamorro Land Trust Commission applicants~~  
4                   ~~on the waiting list starting from the first in line.~~

5                   ~~(3) When the Guam Housing Corporation has exhausted all~~  
6                   ~~4efforts in (1) and (2) above, the Guam Housing Corporation~~  
7                   ~~will announce the availability of lots and receive applications~~  
8                   ~~for interested persons who meet the eligibility requirements of~~  
9                   ~~the original program. If the Guam Housing Corporation~~  
10                  ~~receives more applications than the number of lots available, a~~  
11                  ~~lottery will be used to award the lots.~~

12                  **Section 4. Effective Date.** This Act shall be effective upon  
13                  enactment into law.”







# GHURA

Guam Housing and Urban Renewal Authority  
Aturidat Ginima' Yan Rinueban Siudad Guahan  
117 Bien Venida Avenue, Sinajana, GU 96910  
Phone: (671) 477-9851 · Fax: (671) 300-7565 · TTY: (671) 472-3701



**Eddie Baza Calvo**  
Governor of Guam

**Ray Tenorio**  
Lt. Governor of Guam

**David J. Sablan**  
Chairman

**Ricardo A. Calvo**  
Vice Chairman

**Rosie Ann Blas**  
Member

**Luis L.G. Paulino**  
Member

**Roland M. Selvidge**  
Resident Member

**Cecile B. Suda**  
Member

**Deanne S.N. Torre**  
Member

**Ray S. Topasña**  
Executive Director

**Melinda L. Taitano**  
Acting Deputy Director

## TESTIMONY OF RAY S. TOPASNA

### GHURA EXECUTIVE DIRECTOR

### ON THE MATTER OF BILL 458-31

### AN ACT TO REPEAL AND RE-ENACT SECTION 4 OF PUBLIC LAW 31-209

Madam Chair:

I am Mr. Ray Topasña. I am the Executive Director for the Guam Housing and Urban Renewal Authority.

I am here to testify on Bill No. 458 – 31, An Act to Repeal and Re- Enact Section 4 of Public Law 31 – 209, Relative to the Transfer of Parcels in the Sagan Linahyan Subdivision, Dededo, Guam. GHURA supports the passage of Bill 458.

The subdivision consists of 98 houses of which 96 were sold to families living on government arrendo lots who were displaced by Typhoon Omar. Two families elected to back out of the purchase of the homes at the last minute. To expedite the close-out of the project, FEMA approved the transfer of the remaining 2 lots to the Guam Housing Corporation in 1994.

In 1997 GHURA provided over \$600,000 to the Guam Housing Corporation to assist these families to repair and expand their units. The renovation and expansion project was completed in 1998 with 43 of the 96 families participating in the interest-free renovation loan program.



Early in his administration Governor Calvo toured the Sagan Lintahyan subdivision and drew attention to the blighted conditions in the subdivision. The Guam Housing and Urban Renewal Authority, the Guam Housing Corporation and other government agencies have been assessing ways to improve conditions in this subdivision.

Last year GHURA provided a rehabilitation loan to one of the Sagan Lintahyan families. Efforts to market our homeowner rehabilitation loan program has proven challenging. We are finding that many of the residents living in the subdivision are the children of the original buyers with limited financial resources. We are evaluating the various options to provide assistance to the current residents and still comply with the limitations of the grants available to GHURA.

Renovating the ten abandoned lots identified in Public Law 31-209 for affordable rental purposes is one of several options we are pursuing to stabilize the subdivision. In returning these 10 units to habitability, this will allow us to introduce working families into the neighborhoods.

The provisions of Section 4 of Public Law 31-209 have clouded the timeline for redeveloping the abandoned units into vitally-needed affordable housing. The nature of GHURA's available funding necessitates that we select activities that can be expediently undertaken. GHURA has demonstrated in past efforts, a willingness to commit funds and resources to support the stabilization of the Sagan Lintahyan neighborhood. While our commitment remains steadfast, we must also ensure that the use of funds remains within the construct of grant compliance and timeliness. The repeal and reenactment of Section 4 of Public Law 31-209 as proposed will adequately address the concerns of the Authority.

Thank you for your time.



# GHURA

Guam Housing and Urban Renewal Authority  
Aturidat Ginima' Yan Rinueban Siudad Guahan  
117 Bien Venida Avenue, Sinajana, GU 96910  
Phone: (671) 477-9851 · Fax: (671) 300-7565 · TTY: (671) 472-3701



EQUAL HOUSING  
OPPORTUNITY

May 23, 2012

**Eddie Baza Calvo**  
Governor of Guam

**Ray Tenorio**  
Lt. Governor of Guam

**David J. Sablan**  
Chairman

**Ricardo A. Calvo**  
Vice Chairman

**Rosie Ann Blas**  
Member

**Luis L.G. Paulino**  
Member

**Roland M. Selvidge**  
Resident Member

**Cecile B. Suda**  
Member

**Deanne S.N. Torre**  
Member

**Ray S. Topasña**  
Executive Director

**Melinda L. Taitano**  
Acting Deputy Director

Senator Tina Rose Muna-Barnes  
Chairperson, Committee on Municipal Affairs,  
Tourism, Housing and Recreation  
Suite 101  
155 Hesler Street  
Hagatna, Guam 96910

**SUBJECT: Public Law 31-209, proposal to amend**

Hafa Adai Senator Muna-Barnes:

It is our understanding that your office has been in discussion with the Guam Housing Corporation to amend the recently signed P.L. 31-209, the law authorizing the transfer of 10 housing units in Sagan Linahyan to GHC.

The \$650,000 earmarked for the Linahyan project is part of a \$1.7 million reprogramming package that was recently approved by the U.S. Department of Housing and Urban Development. The total reprogramming will allow GHURA to comply with several grant performance measures. Public service activities cannot exceed 15% of total grant expenditures for the program year. Costs for planning and administrative activities cannot exceed 20% of total grant expenditures for the program year. Based on these expenditure caps it is essential that approximately \$2.0 million in expenditures be incurred in other eligible areas such as new construction, acquisition and renovation activities.

During its February 29, 2012 meeting, the GHURA Board of Commissioners approved management's recommendation to reprogram CDBG funds from completed projects and from projects which had not been implemented to support Governor Calvo's call to increase the number of affordable housing on the island. One of the projects identified was the renovation of ten houses in Sagan Linahyan which were to be transferred from the Government of Guam to the Guam Housing Corporation. The proposed renovation of these ten units was a direct outcome of Governor Calvo's concerns for the state of disrepair in the subdivision, a sentiment he expressed during a tour of the neighborhood early in 2011.

Office of the Legislative Secretary  
Senator Tina Rose Muna-Barnes  
Date 5/23/2012  
Time 12:30 PM  
Received by LOVIN



GHURA's management presented to the Board an aggressive project timeline to ensure that the renovation contract would commence by the beginning of June. Three separate processes were initiated simultaneously so that a contract could be awarded in June and completed by September 2012. These processes include the grant fund reprogramming process, the environmental review record process and the procurement process. The Board of Commissioners was scheduled to approve the awarding of the contract to the lowest responsive and responsible bidder at its meeting on May 24, 2012.

The uncertainty created by P. L. 31-209 has placed GHURA in an untenable position. While we continue to support the goal of improving conditions within the Sagan Linahyan subdivision, we must pursue an immediate alternative use of the \$650,000 allocated to the Sagan Linahyan subdivision. Thus, GHURA has initiated the reprogramming of these funds to renovate staff housing units in Yigo and Dededo.

We support your efforts to redress the provisions of P.L. 31-209 which prevent the use of CDBG (Community Development Block Grant) funding for the rehabilitation of the Linahyan homes for use as affordable rental housing. We have advised GHC Management of our willingness to revisit the Linahyan project in time and after the necessary amendment to the current law have been successfully implemented.

Thank you for your continued support and advocacy of housing issues affecting the people of Guam.

Best Regards,

**RAY S. TOPASNA**  
Executive Director

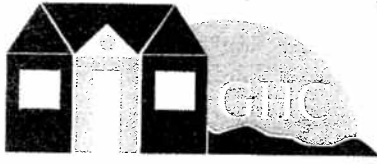

**GUAM HOUSING CORPORATION**

*Korporasion Ginimo' Guahan*

*2000 A.C. Highway, Suite 101*

May 22, 2012

Honorable Tina Rose Muna Barnes  
Senator of the 31<sup>st</sup> Guam Legislature  
155 Hesler Place  
Hagatna, Guam 96910

**RE: PL #31-209 "An Act To Authorize I Maga'lahren Guahan To Transfer Abandoned Properties Located Within Tract Number 1113, Also Known As The Sagan Linahyan Subdivision , from Dipattamentaton Minanehan Tano' (Department of Land Management ) To the Guam Housing Corporation For The Purpose of Affordable Housing"**

Buenas Senator Barnes,

Thank you for allowing our office to meet with you to address our urgent concerns regarding PL #31-209, specifically, "SECTION 4. TRANSFER OF PARCELS". As the author of the legislation in question, the original bill (Bill No. 411-31) as written, allowed the abandoned properties to be transferred from The Department of Land Management (DLM), to The Guam Housing Corporation (GHC), for the purpose of affordable housing. While the intent and the spirit of the law is without question, our concerns with "SECTION 4 – TRANSFER OF PARCELS", an amendment added to your original legislation, will prove to be a detriment to the use and development of the property not only at the current proposed U.S. Department of Housing & Urban Development (HUD) funding, but for all future federal funding at these properties. Furthermore, during the public hearing for the original Bill No. 411-31, it was noted by the Director of Dept. of Land Management, that every effort was made to contact the prospective landowners to comply with the terms of the Contract to Deed, to no avail. This was completed with the guidance of the Attorney General. We would like to reiterate that the condition of the properties were in disrepair, abandoned and inhabitable for many years. Any additional efforts to assign the abandoned properties will just be delaying the inevitable.

As you and your colleagues were made aware, the 10 abandoned properties were to be developed at the expense of HUD – Community Block Grant Development (CDBG) funds, to the tune of \$650,000.00 for the rehabilitation of the housing units and subsequently made available for low-income families for rent. In our meeting on May 18, 2012, with the HUD Program administrators and our partners in this development, GHURA, we were advised that the specific provision / section (SECTION 4 TRANSFER OF PARCELS) of PL #31-209 will deem "this project, and all future projects in the subdivision – "INELIGIBLE"

*590 S. Marine Corps Drive, Ste. 514 ITC Building, Tamuning, Guam 96931  
Telephone Number (671) 647-4143/46 • Fax Number (671) 649-4144*

Additionally and unfortunately, due to HUD funding reprogramming requirements, funding for the "10 Abandoned Properties at Sagan Lintahyan is at risk, due to the deadline requirement of expended funds by the end of Fiscal year September 30, 2012. Our partners at GHURA had issued all required RFP's and utilized many man hours dedicated to the proposed rehabilitation of the Sagan Lintahyan properties. Additionally, the response to the RFP's by sixteen (16) local contractors in a fragile construction industry will pose a negative effect to many contractors and construction companies.

We are requesting immediate action to amend PL #31-209, to remove "SECTION 4 TRANSFER OF PARCELS" and restore your original legislation to form.

We thank you and your office for its unwavering support in our efforts in providing Affordable Housing to the people of Guam.

Once again, thank you for all your support!

Dangkolu Na Si Yu'us Ma'ase,

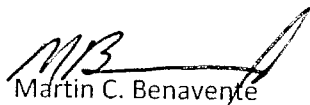
  
Martin C. Benavente  
President

**BUREAU OF BUDGET & MANAGEMENT RESEARCH**

OFFICE OF THE GOVERNOR

Post Office Box 2950, Hagåtña Guam 96932

**EDDIE BAZA CALVO**  
GOVERNOR**RAY TENORIO**  
LIEUTENANT GOVERNOR**JOHN A. RIOS**  
DIRECTOR**STEPHEN J. GUERRERO**  
DEPUTY DIRECTOR

MAY 25 2012

The Bureau requests that Bill No. 458-31 (COR) be granted a waiver pursuant to Public Law 12-229 as amended for the following reason(s):

The Bill is administrative in nature as the intent is to repeal and re-enact Section 4 of Public Law 31-209 relative to the transfer of parcels in the Sagan Linahyan Subdivision, Dededo, Guam. The subject section stipulates step-by-step requirements that Guam Housing Corporation needs to fulfill in the distribution of the lots to qualified individuals for residential use.

The passage of this Bill would not have a financial impact on the Government of Guam.

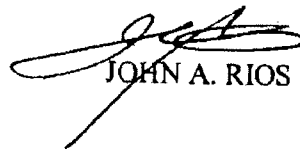
  
JOHN A. RIOS



# COMMITTEE ON RULES

*I Mina'trentai Unu na Liheslaturan Guåhan* • The 31<sup>st</sup> Guam Legislature  
155 Hesler Place, Hagåtña, Guam 96910 • [www.guamlegislature.com](http://www.guamlegislature.com)  
E-mail: [roryforguam@gmail.com](mailto:roryforguam@gmail.com) • Tel: (671)472-7679 • Fax: (671)472-3547

Senator  
Rory J. Respicio  
CHAIRPERSON  
MAJORITY LEADER

Senator  
Judith P. Guthertz  
VICE CHAIRPERSON  
ASST. MAJORITY LEADER

**MAJORITY MEMBERS:**

Speaker  
Judith T. Won Pat

Vice Speaker  
Benjamin J. F. Cruz

Senator  
Tina Rose Muña Barnes  
LEGISLATIVE SECRETARY  
MAJORITY WHIP

Senator  
Dennis G. Rodriguez, Jr.  
ASST. MAJORITY WHIP

Senator  
Thomas C. Ada

Senator  
Adolpho B. Palacios, Sr.

Senator  
vicente c. pangclinan

**MINORITY MEMBERS:**

Senator  
Aline A. Yamashita  
ASST. MINORITY LEADER

Senator  
Christopher M. Duenas

May 21, 2012

**MEMORANDUM**

**To:** Pat Santos  
*Clerk of the Legislature*

**Attorney Therese M. Terlaje**  
*Legislative Legal Counsel*

**From:** Senator Rory J. Respicio  
*Majority Leader & Rules Chair*

**Subject:** Referral of Bill Nos. 457-31 (COR) & 458-31 (COR)

As the Chairperson of the Committee on Rules, I am forwarding my referral of Bill Nos. 457-31 (COR) and 458-31 (COR).

Please ensure that the subject bills are referred, in my name, to the respective committee, as shown on the attachment. I also request that the same be forwarded to all members of *I Mina'trentai Unu na Liheslaturan Guåhan*.

Should you have any questions, please feel free to contact our office at 472-7679.

*Si Yu'os Ma'åse!*

(2) Attachment



*I Mina'Trentai Unu Na Liheslaturan Guahan*  
**Bill Log Sheet**

ONSOR	TITLE	DATE INTRODUCED	DATE REFERRED	120 DAY DEADLINE	CMTE REFERRED	PUBLIC HEARING DATE	DATE COMMITTEE REPORT FILED
una Barnes	AN ACT TO REPEAL AND RE-ENACT SECTION 4 OF PUBLIC LAW 31-209, RELATIVE TO THE TRANSFER OF PARCELS IN THE SAGAN LINAHYAN SUBDIVISION, DEDED0, GUAM.	5/18/12 5:18 p.m.	5/21/12		Committee on Municipal Affairs, Tourism, Housing and Recreation		



**I Mina'Trentai Unu Na Liheslaturan Guåhan**  
**Office of The Legislative Secretary**  
**Tina Rose Muña Barnes**

---

May 22, 2012

**Memorandum**

**TO:** All Members/All Senators

**FROM:** Senator Tina Rose Muña Barnes *✍*

**SUBJECT:** First Notice of Public Hearing  
Wednesday, May 30, 2012

*Hafa Adai!*

The Committee on Municipal Affairs, Tourism, Housing and Recreation will be conducting a public hearing on **Wednesday, May 30, 2012** in the Legislature's Public Hearing Room, beginning at 6:00 p.m. This hearing is scheduled to receive public testimony on the following:

- **Bill No. 463-31 (COR)** An act to adopt the Guam Housing Corporation Administrative Rules and Regulations for the implementation of the First-Time Homeowners Assistance Program
- **Bill No. 458-31 (COR)** An act to repeal and re-enact Section 4 of Public Law 31-209, relative to the transfer of parcels in the Sagan Linahyan Subdivision, Dededo, Guam

Written testimonies may be submitted on the day of, prior to, or up to ten days after the public hearing to the Office of Senator Tina Rose Muña Barnes, 155 Hesler Place, Hagatña Guam 96910, via facsimile to 472-3400 or via email to [senator@tinamunabarnes.com](mailto:senator@tinamunabarnes.com). We comply with Title II of the Americans with Disabilities Act (ADA). Should you require assistance or accommodations please contact Jeanenne Cordero or John Blas from our office at 472-3455/6 or via email at [jean@tinamunabarnes.com](mailto:jean@tinamunabarnes.com) or [jblas@tinamunabarnes.com](mailto:jblas@tinamunabarnes.com). I look forward to your attendance and participation.

*Si Yu'os Ma'åse'!*

cc: Sergeant-At-Arms/Protocol/AV  
Clerk of the Legislature  
MIS  
All Media

---

Chairperson, Committee on Municipal Affairs, Tourism, Housing and Recreation  
Vice Chairperson, Committee on Youth, Cultural Affairs, Procurement, General Government Operations and Public Broadcasting  
155 Hesler Place Hagatña, Guam 96910 [Tel: 671-472-3455/6 Fax: 671-472-3400] [www.tinamunabarnes.com](http://www.tinamunabarnes.com)



Jean Cordero &lt;jean@tinamunabarnes.com&gt;

---

**First Notice of Public Hearing**

10 messages

---

**Jean Cordero** <jean@tinamunabarnes.com>

Tue, May 22, 2012 at 4:59 PM

To: phnotice@guamlegislature.org

Cc: Regine Lee &lt;regine@tinamunabarnes.com&gt;, John Blas &lt;jblas@tinamunabarnes.com&gt;, Uriah Perez &lt;uriah@tinamunabarnes.com&gt;

Hafa adai all! Please see attached memo of First Notice of Public Hearing on Wednesday, May 30, 2012 at 6:00 p.m. in the Public Hearing Room. Thank you!

--

*Jeanenne P. Cordero "Jean"**Office Manager**Office of Senator Tina Rose Muna Barnes**Tel: 671-472-3455/6**Fax: 671-472-3400**e-mail: jean@tinamunabarnes.com*

---

 **First Notice.pdf**  
59K

---

**Regine B. Lee (Office of Senator Tina Muna Barnes)**

&lt;regine@tinamunabarnes.com&gt;

Tue, May 22, 2012 at 5:15 PM

To: Jean Cordero &lt;jean@tinamunabarnes.com&gt;

You're a rockstar!

Thanks so much for your help, Jean!!

The Senator still wants to do expedite the Sagan Linahyan bill & will need a letter to the Speaker requesting it be put on as emergency legislation, so we dont lose out on \$600,000 in grant funding. Can you send me a template or draft tomorrow?

Thanks again! \*regine

[Quoted text hidden]

--

Régine Biscoe Lee

Chief of Staff

Office of Senator Tina Rose Muña Barnes

Committee on Municipal Affairs, Tourism, Housing and Recreation

155 Hessler Place | Hagåtña, Guam 96910

(W) 671.472.3455/6 | (F) 671.472.3400

email:regine@tinamunabarnes.com

---

\*Please consider the environment before printing this email.

---

**jean@tinamunabarnes.com** <jean@tinamunabarnes.com>

Tue, May 22, 2012 at 5:17 PM

Reply-To: jean@tinamunabarnes.com

To: "Regine B. Lee (Office of Senator Tina Muna Barnes)" &lt;regine@tinamunabarnes.com&gt;

I'll write a letter first thing tomorrow to be dated thursday cuz that's when the speaker returns.

[Quoted text hidden]

Sent from my BlackBerry® wireless device

---

**regine@tinamunabarnes.com** <regine@tinamunabarnes.com>

Tue, May 22, 2012 at 5:30 PM

Reply-To: regine@tinamunabarnes.com

To: Jean Cordero <jean@tinamunabarnes.com>

Sounds good. If Senator is ok w/ manenggon agenda, can you please print enough for attendees?

Thanks, OMGG! :)

Sent from my BlackBerry® smartphone

www.blackberry.com

[Quoted text hidden]

---

**jean@tinamunabarnes.com** <jean@tinamunabarnes.com>

Tue, May 22, 2012 at 5:48 PM

Reply-To: jean@tinamunabarnes.com

To: regine@tinamunabarnes.com

Did u send me the agends?

Sent from my BlackBerry® wireless device

[Quoted text hidden]

---

**regine@tinamunabarnes.com** <regine@tinamunabarnes.com>

Tue, May 22, 2012 at 6:00 PM

Reply-To: regine@tinamunabarnes.com

To: Jean Cordero <jean@tinamunabarnes.com>

I believe so. Let me know if u didn't get it & ill resend. \*regine

Sent from my BlackBerry® smartphone

www.blackberry.com

-----Original Message-----

From: jean@tinamunabarnes.com

[Quoted text hidden]

---

**jean@tinamunabarnes.com** <jean@tinamunabarnes.com>

Tue, May 22, 2012 at 6:30 PM

Reply-To: jean@tinamunabarnes.com

To: regine@tinamunabarnes.com

I received it so I'll print it in the morning. Thank you!

Sent from my BlackBerry® wireless device

-----Original Message-----

From: regine@tinamunabarnes.com

[Quoted text hidden]

---

**regine@tinamunabarnes.com** <regine@tinamunabarnes.com>

Tue, May 22, 2012 at 6:39 PM

Reply-To: regine@tinamunabarnes.com

To: Jean Cordero <jean@tinamunabarnes.com>

Awesome. Thanks again!

Sent from my BlackBerry® smartphone

www.blackberry.com

-----Original Message-----

From: jean@tinamunabarnes.com

[Quoted text hidden]

---

**jean@tinamunabarnes.com** <jean@tinamunabarnes.com>  
Reply-To: jean@tinamunabarnes.com  
To: regine@tinamunabarnes.com

Tue, May 22, 2012 at 6:44 PM

No problem girl! We r a TEAM!  
Sent from my BlackBerry® wireless device

-----Original Message-----

From: regine@tinamunabarnes.com

[Quoted text hidden]

---

**Adam Bearce** <adam@guamlegislature.org>

Wed, May 23, 2012 at 8:28 AM

To: Jean Cordero <jean@tinamunabarnes.com>, Yong Pak <yong@guamlegislature.org>

Hi. This is now posted.

On Tue, May 22, 2012 at 4:59 PM, Jean Cordero <jean@tinamunabarnes.com> wrote:

[Quoted text hidden]

**Listserv: [phnotice@guamlegislature.org](mailto:phnotice@guamlegislature.org)**

**As of Jan. 30, 2012**

aguon4guam@gmail.com  
alerta.jermaine@gmail.com  
aline4families@gmail.com  
ataylor.senatordrodriguez@gmail.com  
audrey@judiwonpat.com  
baza.matthew@gmail.com  
berlene@senatorpalacios.com  
bruce.lloyd.media@gmail.com  
candasofrank@gmail.com  
chechsantos@gmail.com  
cherbert.senatordrodriguez@gmail.com  
cipo@guamlegislature.org  
clerks@guamlegislature.org  
colleen@judiwonpat.com  
cor@guamlegislature.org  
cyrus@senatorada.org  
doc.wyittenbachsantos@gmail.com  
duenasenator@gmail.com  
edleonguerrero@gmail.com  
edpocaigne@judiwonpat.com  
edwardglee671@yahoo.com  
elaine@tinamunabarnes.com  
etajalle@guamlegislature.org  
evelyn4families@gmail.com  
faith.r@senatormabini.com  
faith.r@senatormabini.com  
fbtorres@judiwonpat.com  
floterlaje@gmail.com  
frank.blasjr@gmail.com  
gavin@tinamunabarnes.com  
guamnativesun@yahoo.com  
jamespcastro@gmail.com  
jane@tinamunabarnes.com  
jason@senatorpalacios.com  
jcamacho@senatorada.com  
jean@tinamunabarnes.com  
jeff.m@senatormabini.com  
jennifer@senatorpalacios.com  
jimespaldon@yahoo.com  
jmesngon.senatordrodriguez@gmail.com  
john.calvo@noaa.gov  
jtenorio@guamcourts.org  
judiguthertz@gmail.com  
julian@senatorpalacios.com  
leonguerrero.angela@gmail.com  
lou4families@gmail.com  
louise\_atalig@yahoo.com  
markaflague@gmail.com  
maryfejeran@gmail.com  
mcarlson@guamlegislature.org  
mis@guamlegislature.org  
msuarez.senatordrodriguez@gmail.com  
mtorres.senatordrodriguez@gmail.com  
myracle.m@senatormabini.com  
nsantos@senatorada.org  
office@senatorada.org  
oliviampalacios@gmail.com  
peterlg@gmail.com  
phillipsguam@gmail.com  
pris@senatorpalacios.com  
regine@tinamunabarnes.com  
rfteehan@yahoo.com  
rob.tupaz@gmail.com  
roryforguam@gmail.com  
Santos.duenas@gmail.com  
sem@guamlegislature.org  
senator@senatorbjcruz.com  
senator@senatorpalacios.com  
senator@tinamunabarnes.com  
senatordrodriguez@gmail.com  
senatormabini@senatormabini.com  
senatorsam@senatormabini.com  
senatortonyada@guamlegislature.org  
senbenp@guam.net  
sgrarmes@guamlegislature.org  
speaker@judiwonpat.com  
tanya4families@gmail.com  
tcastro@guam.net  
telo.taitague@guam.gov  
tinaokada@gmail.com  
tom@senatorada.org  
tterlaje@guam.net  
uriah@tinamunabarnes.com  
val.g@senatormabini.com  
vkomiyama.senatordrodriguez@gmail.com  
wilcastro671@gmail.com



Jean Cordero <jean@tinamunabarnes.com>

**First Notice of Public Hearing**

3 messages

**Jean Cordero** <jean@tinamunabarnes.com>

Tue, May 22, 2012 at 5:00 PM

To: amier@mvguam.com, clynt@spbgum.com, dcrisost@guampdn.com, dmgeorge@guampdn.com, editor@mvguam.com, egthompson@guampdn.com, jason@kuam.com, jtyquiengco@spbgum.com, kstokish@gmail.com, kstone@ite.net, life@guampdn.com, mabuhaynews@yahoo.com, mindy@kuam.com, news@guampdn.com, news@spbgum.com, nick.delgado@kuam.com, rlimtiaco@guampdn.com, sabrina@kuam.com, slimtiaco@guampdn.com, telo.taitague@guam.gov, zita@mvguam.com, "mpieper@guampdn.com" <mpieper@guampdn.com>, "officemanager@hitradio100.com" <officemanager@hitradio100.com>, "ricknauta@hitradio100.com" <ricknauta@hitradio100.com>

Hafa adai all! Please see attached memo of First Notice of Public Hearing on Wednesday, May 30, 2012 at 6:00 p.m. in the Public Hearing Room. Thank you!

--  
 Jeanenne P. Cordero "Jean"  
 Office Manager  
 Office of Senator Tina Rose Muna Barnes  
 Tel: 671-472-3455/6  
 Fax: 671-472-3400  
 e-mail: jean@tinamunabarnes.com

**First Notice.pdf**  
 59K

**MAILER-DAEMON@pobox.ite.net** <MAILER-DAEMON@pobox.ite.net>

Tue, May 22, 2012 at 5:00 PM

To: jean@tinamunabarnes.com

Hi. This is the qmail-send program at pobox.ite.net.  
 I'm afraid I wasn't able to deliver your message to the following addresses.  
 This is a permanent error; I've given up. Sorry it didn't work out.

<kstone@ite.net>:  
 maildrop: maildir over quota.

--- Below this line is a copy of the message.

Return-Path: <jean@tinamunabarnes.com>  
 Received: (qmail 18895 invoked from network); 22 May 2012 17:00:18 +1000  
 Received: from unknown (HELO otherguy.pti1.com) (172.17.0.13)  
 by pobox.ite.net with SMTP; 22 May 2012 17:00:18 +1000  
 Received: (qmail 7274 invoked from network); 22 May 2012 17:00:18 +1000  
 Received: by simscan 1.4.0 ppid: 7249, pid: 7252, t: 8.1092s  
 scanners: clamav: 0.97/m:54/d:14945 spam: 3.2.5  
 X-Spam-Checker-Version: SpamAssassin 3.2.5 (2008-06-10) on otherguy.pti1.com  
 X-Spam-Level:  
 X-Spam-Status: No, score=-22.3 required=8.5 tests=AWL,BAYES\_00,HTML\_MESSAGE,RCVD\_IN\_DNSWL\_LOW,SPF\_CHECK\_NONE autolearn=ham version=3.2.5  
 Received: from mail-yw0-f45.google.com (209.85.213.45)  
 by otherguy.pti1.com with SMTP; 22 May 2012 17:00:10 +1000  
 Received-SPF: none (otherguy.pti1.com: domain at tinamunabarnes.com does not designate permitted sender



Jean Cordero <jean@tinamunabarnes.com>

---

## First Notice of Public Hearing

1 message

---

**Jean Cordero** <jean@tinamunabarnes.com>

Tue, May 22, 2012 at 5:01 PM

To: martin.benavente@ghc.guam.gov, rtopasna@ghura.org, Millie Taitano <mtaitano@ghura.org>

Hafa adai all! Please see attached memo of First Notice of Public Hearing on Wednesday, May 30, 2012 at 6:00 p.m. in the Public Hearing Room. Thank you!

--

*Jeanenne P. Cordero "Jean"*

*Office Manager*

*Office of Senator Tina Rose Muna Barnes*

*Tel: 671-472-3455/6*

*Fax: 671-472-3400*

*e-mail: jean@tinamunabarnes.com*

---

 **First Notice.pdf**  
59K





**I Mina'Trentai Unu Na Liheslaturan Guåhan**  
**Office of The Legislative Secretary**  
**Tina Rose Muña Barnes**

---

May 25, 2012

**Memorandum**

**TO:** All Members/All Senators

**FROM:** Senator Tina Rose Muña Barnes

**SUBJECT:** Second Notice of Public Hearing  
Wednesday, May 30, 2012

*Hafa Adai!*

The Committee on Municipal Affairs, Tourism, Housing and Recreation will be conducting a public hearing on **Wednesday, May 30, 2012** in the Legislature's Public Hearing Room, beginning at 6:00 p.m. This hearing is scheduled to receive public testimony on the following:

- **Bill No. 463-31 (COR)** An act to adopt the Guam Housing Coporation Administrative Rules and Regulations for the implementation of the First-Time Homeowners Assistance Program
- **Bill No. 458-31 (COR)** An act to repeal and re-enact Section 4 of Public Law 31-209, relative to the transfer of parcels in the Sagan Linahyan Subdivision, Dededo, Guam

Written testimonies may be submitted on the day of, prior to, or up to ten days after the public hearing to the Office of Senator Tina Rose Muña Barnes, 155 Hesler Place, Hagatña Guam 96910, via facsimile to 472-3400 or via email to [senator@tinamunabarnes.com](mailto:senator@tinamunabarnes.com). We comply with Title II of the Americans with Disabilities Act (ADA). Should you require assistance or accommodations please contact Jeanenne Cordero or John Blas from our office at 472-3455/6 or via email at [jean@tinamunabarnes.com](mailto:jean@tinamunabarnes.com) or [jblas@tinamunabarnes.com](mailto:jblas@tinamunabarnes.com). I look forward to your attendance and participation.

*Si Yu'os Ma'åse'!*

cc: Sergeant-At-Arms/Protocol/AV  
Clerk of the Legislature  
MIS  
All Media

---

Chairperson, Committee on Municipal Affairs, Tourism, Housing and Recreation  
Vice Chairperson, Committee on Youth, Cultural Affairs, Procurement, General Government Operations and Public Broadcasting  
155 Hesler Place Hagatña, Guam 96910 [Tel: 671-472-3455/6 Fax: 671-472-3400] [www.tinamunabarnes.com](http://www.tinamunabarnes.com)



Jean Cordero &lt;jean@tinamunabarnes.com&gt;

---

**Second Notice of Public Hearing**

3 messages

---

**Jean Cordero** <jean@tinamunabarnes.com>

Fri, May 25, 2012 at 11:40 AM

To: phnotice@guamlegislature.org

Cc: Regine Lee &lt;regine@tinamunabarnes.com&gt;, John Blas &lt;jblas@tinamunabarnes.com&gt;

Good morning all! Please see attached memo of Second Notice for a Public Hearing that will be held on Wednesday, May 30, 2012 beginning at 6:00 p.m. in the Public Hearing Room. Thank you and have a wonderful afternoon!

--  
*Jeanenne P. Cordero "Jean"*  
*Office Manager*  
*Office of Senator Tina Rose Muna Barnes*  
*Tel: 671-472-3455/6*  
*Fax: 671-472-3400*  
*e-mail: jean@tinamunabarnes.com*

---

 **Second Notice of May 30 Public Hearing.pdf**  
55K

---

**regine@tinamunabarnes.com** <regine@tinamunabarnes.com>

Fri, May 25, 2012 at 11:41 AM

Reply-To: regine@tinamunabarnes.com

To: Jean Cordero &lt;jean@tinamunabarnes.com&gt;

Jean, you're a gem. Thanks so much!!  
Sent from my BlackBerry® smartphone  
www.blackberry.com

---

**From:** Jean Cordero <jean@tinamunabarnes.com>**Date:** Fri, 25 May 2012 11:40:28 +1000**To:** <phnotice@guamlegislature.org>**Cc:** Regine Lee <regine@tinamunabarnes.com>; John Blas <jblas@tinamunabarnes.com>**Subject:** Second Notice of Public Hearing

[Quoted text hidden]

---

**Adam Bearce** <adam@guamlegislature.org>

Fri, May 25, 2012 at 11:51 AM

To: Jean Cordero &lt;jean@tinamunabarnes.com&gt;, Yong Pak &lt;yong@guamlegislature.org&gt;

hi. confirmed posted.

[Quoted text hidden]

aguon4guam@gmail.com  
alerta.jermaine@gmail.com  
aline4families@gmail.com  
ataylor.senatorrodriguez@gmail.com  
audrey@judiwonpat.com  
baza.matthew@gmail.com  
berlene@senatorpalacios.com  
bruce.lloyd.media@gmail.com  
candasofrank@gmail.com  
chechsantos@gmail.com  
cherbert.senatorrodriguez@gmail.com  
cipo@guamlegisalature.org  
clerks@guamlegisalature.org  
colleen@judiwonpat.com  
cor@guamlegislature.org  
cyrus@senatorada.org  
doc.wyppenbachsantos@gmail.com  
duenasenator@gmail.com  
edleonguerrero@gmail.com  
edpocaigue@judiwonpat.com  
edwardglee671@yahoo.com  
elaine@tinamunabarnes.com  
etajalle@guamlegislature.org  
evelyn4families@gmail.com  
faith.r@senatormabini.com  
faith.r@senatormabini.com  
fbtorres@judiwonpat.com  
floterlaje@gmail.com  
frank.blasjr@gmail.com  
gavin@tinamunabarnes.com  
guamnativesun@yahoo.com  
jamespcastro@gmail.com  
jane@tinamunabarnes.com  
jason@senatorpalacios.com  
jcamacho@senatorada.com  
jean@tinamunabarnes.com  
jeff.m@senatormabini.com  
jennifer@senatorpalacios.com  
jimespaldon@yahoo.com  
jmesngon.senatorrodriguez@gmail.com  
john.calvo@noaa.gov  
jtenorio@guamcourts.org  
judiguthertz@gmail.com  
julian@senatorpalacios.com  
leonguerrero.angela@gmail.com  
lou4families@gmail.com  
louise\_atalig@yahoo.com  
markaflague@gmail.com  
maryfejeran@gmail.com  
mcarlson@guamlegislature.org  
mis@guamlegislature.org  
msuarez.senatorrodriguez@gmail.com  
mtorres.senatorrodriguez@gmail.com  
myracle.m@senatormabini.com  
nsantos@senatorada.org  
office@senatorada.org  
oliviampalacios@gmail.com  
peterlg@gmail.com  
phillipsguam@gmail.com  
pris@senatorpalacios.com  
regine@tinamunabarnes.com  
rfttehan@yahoo.com  
rob.tupaz@gmail.com  
roryforguam@gmail.com  
Santos.duenas@gmail.com  
sem@guamlegislature.org  
senator@senatorbjcruz.com  
senator@senatorpalacios.com  
senator@tinamunabarnes.com  
senatorrodriguez@gmail.com  
senatormabini@senatormabini.com  
senatorsam@senatormabini.com  
senatorTonyada@guamlegislature.org  
senbenp@guam.net  
sgrarmes@guamlegislature.org  
speaker@judiwonpat.com  
tanya4families@gmail.com  
tcastro@guam.net  
telo.taitague@guam.gov  
tinaokada@gmail.com  
tom@senatorada.org  
tterlaje@guam.net  
uriah@tinamunabarnes.com  
val.g@senatormabini.com  
vkomiyama.senatorrodriguez@gmail.com  
wilcastro671@gmail.com



Jean Cordero &lt;jean@tinamunabarnes.com&gt;

---

**Second Notice of May 30 Public Hearing**

1 message

---

**Jean Cordero** <jean@tinamunabarnes.com>

Fri, May 25, 2012 at 11:42 AM

To: amier@mvguam.com, clynt@spbguam.com, dcrisost@guampdn.com, dmgeorge@guampdn.com, editor@mvguam.com, jason@kuam.com, jtyquiengco@spbguam.com, kstokish@gmail.com, life@guampdn.com, mabuhaynews@yahoo.com, mindy@kuam.com, news@guampdn.com, news@spbguam.com, nick.delgado@kuam.com, rlimtiaco@guampdn.com, sabrina@kuam.com, slimtiaco@guampdn.com, telo.taitague@guam.gov, zita@mvguam.com, "mpieper@guampdn.com" <mpieper@guampdn.com>, "officemanager@hitradio100.com" <officemanager@hitradio100.com>, "ricknauta@hitradio100.com" <ricknauta@hitradio100.com>

Good morning all! Please see attached memo of Second Notice for Public Hearing on May 30, 2012 beginning at 6:00 p.m. in the Public Hearing Room. Thank you and have a wonderful afternoon!

--

*Jeanenne P. Cordero "Jean"*  
*Office Manager*  
*Office of Senator Tina Rose Muna Barnes*  
*Tel: 671-472-3455/6*  
*Fax: 671-472-3400*  
*e-mail: jean@tinamunabarnes.com*

---

 **Second Notice of May 30 Public Hearing.pdf**  
55K



Jean Cordero <jean@tinamunabarnes.com>

---

## Second Notice of Public Hearing on May 30

1 message

---

**Jean Cordero** <jean@tinamunabarnes.com>

Fri, May 25, 2012 at 11:46 AM

To: rtopasna@ghura.org, Millie Taitano <mtaitano@ghura.org>, martin.benavente@ghc.guam.gov  
Cc: djsablan@guam.net

Hafa adai and good morning! Please see attached memo of Second Notice for Public Hearing on May 30, 2012 beginning at 6:00 p.m. in the Public Hearing Room. Thank you and have a wonderful afternoon!

--

*Jeanenne P. Cordero "Jean"*  
*Office Manager*  
*Office of Senator Tina Rose Muna Barnes*  
*Tel: 671-472-3455/6*  
*Fax: 671-472-3400*  
*e-mail: jean@tinamunabarnes.com*

---

 **Second Notice of May 30 Public Hearing.pdf**  
55K



*I Mina'Trentai Unu Na Liheslaturan Guåhan*  
Office of The Legislative Secretary  
Tina Rose Muña Barnes

---

**PUBLIC HEARING**  
**Wednesday, May 30, 2012**

**AGENDA**

- I. CALL TO ORDER**
- II. ANNOUNCEMENT**
- III. ITEMS FOR PUBLIC CONSIDERATION**

**6:00 PM**

To hear testimony on the following:

- **Bill No. 463-31 (COR)** An act to adopt the Guam Housing Corporation Administrative Rules and Regulations for the implementation of the First-Time Homeowners Assistance Program
- **Bill No. 458-31 (COR)** An act to repeal and re-enact Section 4 of Public Law 31-209, relative to the transfer of parcels in the Sagan Linahyan Subdivision, Dededo, Guam

- IV. REMARKS**
- V. ADJOURNMENT**

*Electronic copies of the aforementioned items can be found on the Guam Legislature's website at [www.guamlegislature.com](http://www.guamlegislature.com). Hard copies can be obtained by visiting the Office of the Clerk of the Legislature. Testimony should be addressed to Senator Tina Rose Muña Barnes, Chairperson, and may be submitted via hand-delivery to our office or our mailbox at the Main Legislature Building at 155 Hesler Place, Hagatña, Guam 96910, via e-mail to [senator@tinamunabarnes.com](mailto:senator@tinamunabarnes.com) or via facsimile to (671) 472-3400. Individuals requiring special accommodations, auxiliary aids, or services shall contact and submit their request to Jeanenne Cordero at our office. For further information, please call 472-3455/6. I look forward to your attendance and participation. Si Yu'os Ma'åse'!*

*MINA' TRENTAI UNU NA LIHESLATURAN GUÅHAN*  
2012 (SECOND) Regular Session

Bill No. 458-31 (C.O.P.)

Introduced by:

T. R Muña Bages

2012 MAY 15 PM 1:18

**AN ACT TO REPEAL AND RE-ENACT SECTION 4 OF PUBLIC LAW 31-209, RELATIVE TO THE TRANSFER OF PARCELS IN THE SAGAN LINAHYAN SUBDIVISION, DEDEDO, GUAM.**

**BE IT ENACTED BY THE PEOPLE OF GUAM:**

**Section 1.** Section 4 of Public Law 31-209 is hereby *repealed* and *re-enacted* to read:

~~"Section 4. Transfer of Parcels. Prior to the transfer of parcels within the Sagan Linahyan Subdivision, Dededo, Guam, from the Department of Land Management to the Guam Housing Corporation, the Guam Housing Corporation shall:~~

~~(1) Publish in a newspaper of general circulation, the names of the given individuals who had contractual agreements to purchase the lot and be given the opportunity to fulfill their contractual agreement. Heirs of the persons who were awarded the lots should be allowed to fulfill their contractual agreement if they meet the eligibility requirements. If there is more than one (1) heir, the lot or lots shall be drawn by lottery if not in probate or in a will or by quitclaim of all other heirs.~~

1                   ~~(2) If lots are still available after going through the process~~  
2                   ~~as outlined in (1) above, said lots shall be made available to~~  
3                   ~~the eligible Chamorro Land Trust Commission applicants~~  
4                   ~~on the waiting list starting from the first in line.~~

5                   ~~(3) When the Guam Housing Corporation has exhausted all~~  
6                   ~~efforts in (1) and (2) above, the Guam Housing Corporation~~  
7                   ~~will announce the availability of lots and receive applications~~  
8                   ~~for interested persons who meet the eligibility requirements of~~  
9                   ~~the original program. If the Guam Housing Corporation~~  
10                   ~~receives more applications than the number of lots available, a~~  
11                   ~~lottery will be used to award the lots.~~

12                   **Section 4. Effective Date.** This Act shall be effective upon  
13                   enactment into law.”





EDDIE BAZA CALVO  
Governor

RAY TENORIO  
Lieutenant Governor

*Office of the Governor of Guam*

May 14, 2012

Honorable Judith T. Won Pat, Ed.D.  
Speaker  
*I Mina'trentai Unu Na Liheslaturan Guåhan*  
155 Hesler Street  
Hagåtña, Guam 96910

7  
3-12-1500  
Office of the Speaker  
Judith T. Won Pat, Ed. D.  
Date 5/15/12  
Time 4:00 PM  
Received by

Dear Speaker Won Pat:

Transmitted herewith is Bill No. 411-31 (COR) entitled, "AN ACT TO AUTHORIZE *I MAGA'LAHEN GUAHAN* TO TRANSFER ABANDONED PROPERTIES LOCATED WITHIN TRACT NUMBER 1113, ALSO KNOWN AS THE *SAGAN LINAHYAN* SUBDIVISION, FROM THE *DIPATTAMENTON MINANEHAN TANO'* (DEPARTMENT OF LAND MANAGEMENT) TO THE GUAM HOUSING CORPORATION FOR THE PURPOSE OF AFFORDABLE HOUSING", which I signed into law on May 9, 2012 as Public Law 31-209.

*Senseramente,*

EDDIE BAZA CALVO

2012 MAY 16 AM 8:47

Attachment: copy of Bill

1507

*I MINA'TRENTAI UNU NA LIHESLATURAN GUÅHAN*  
2012 (SECOND) Regular Session

**Bill No. 411-31 (COR)**

As amended by the Committee on Appropriations, Taxation,  
Banking, Insurance, Retirement, and Land.

Introduced by:

T. R Muña Barnes  
Judith T. Won Pat, Ed.D.  
T. C. Ada  
V. Anthony Ada  
F. F. Blas, Jr.  
B. J.F. Cruz  
Chris M. Dueñas  
Judith P. Guthertz, DPA  
Sam Mabini, Ph.D.  
T. R. Muña Barnes  
Adolpho B. Palacios, Sr.  
v. c. pangelinan  
Dennis G. Rodriguez, Jr.  
R. J. Respicio  
M. Silva Taijeron  
Aline A. Yamashita, Ph.D.

**AN ACT TO AUTHORIZE *I MAGA'LAHEN GUÅHAN* TO  
TRANSFER ABANDONED PROPERTIES LOCATED  
WITHIN TRACT NUMBER 1113, ALSO KNOWN AS  
THE *SAGAN LINAHYAN* SUBDIVISION, FROM THE  
*DIPÅTTAMENTON MINANEHAN TÅNO'*  
(DEPARTMENT OF LAND MANAGEMENT) TO THE  
GUAM HOUSING CORPORATION FOR THE PURPOSE  
OF AFFORDABLE HOUSING.**

1 **BE IT ENACTED BY THE PEOPLE OF GUAM:**

2 **Section 1. Legislative Findings.** *I Liheslaturan Guåhan* finds that Public  
3 Laws 21-60, 21-72, and 21-146, gave the Department of Land Management the

1 municipality of *Dededo*, containing an area of six hundred three (603) $\pm$   
2 square meters or six thousand four hundred eighty-seven (6,487) $\pm$  square  
3 feet, as shown on a map prepared by Land Management, No. I4-94T561,  
4 L.M. Check No. 214FY94, Subdivision Survey Map of Tract 1113, formerly  
5 Lot No. 10125-11-1, recorded under Document No. 503994, Certificates of  
6 Title No. 35085, Estate No. 22092 together with a three (3)-bedroom  
7 structure. Water and power (electricity) and sewer are immediately  
8 available or within a distance of one hundred (100) feet from the property.

9 (b) Lot No. 12, Block No. 12, Tract No. 1113, GOV/FEMA  
10 Emergency Housing Project, Government of Guam Subdivision,  
11 municipality of *Dededo*, containing an area of five hundred sixty-four  
12 (564) $\pm$  square meters or six thousand sixty-eight (6,068) $\pm$  square feet, as  
13 shown on a map prepared by Land Management, No. I4-94T561, L.M.  
14 Check No. 214FY94 Subdivision Survey Map of Tract 1113, formerly Lot  
15 No. 10125-11-1, recorded under Document No. 503994, Certificates of  
16 Title No. 35085, Estate No. 22092 together with a three (3)-bedroom  
17 structure. Water and power (electricity) and sewer are immediately  
18 available or within a distance of one hundred (100) feet from the property.

19 (c) Lot No. 14, Block No. 12, Tract No. 1113, GOV/FEMA  
20 Emergency Housing Project, Government of Guam Subdivision,  
21 municipality of *Dededo*, containing an area of five hundred sixty-four  
22 (564) $\pm$  square meters or six thousand sixty-eight (6,068) $\pm$  square feet, as  
23 shown on a map prepared by Land Management, No. I4-94T561, L.M.  
24 Check No. 214FY94, Subdivision Survey Map of tract 1113, formerly lot  
25 No. 10125-11-1, recorded under Document No. 503994, Certificates of Title  
26 No. 35085, Estate No. 22092 together with a three (3) bedroom structure.

1 94T561, L.M. Check No. 214FY94, Subdivision Survey Map of Tract 1113,  
2 formerly Lot No. 10125-11-1, recorded under Document No. 503994,  
3 Certificates of Title No. 35085, Estate No. 22092 together with a one (1)  
4 bedroom structure. Water and power (electricity) and sewer are immediately  
5 available or within a distance of one hundred (100) feet from the property.

6 (g) Lot No. 18, Block No. 7, Tract No. 1113, GOV/FEMA  
7 Emergency Housing Project, Government of Guam Subdivision,  
8 municipality of *Dededo*, containing an area of four hundred eighty-two  
9 (482) $\pm$  square meters or five thousand one hundred eighty-nine (5,189) $\pm$   
10 square feet, as shown on a map prepared by Land Management, No. I4-  
11 94T561, L.M. Check No. 214FY94, Subdivision Survey Map of Tract 1113,  
12 formerly Lot No. 10125-11-1, recorded under Document No. 503994,  
13 Certificates of Title No. 35085, Estate No. 22092 together with a one (1)  
14 bedroom structure. Water and power (electricity) and sewer are immediately  
15 available or within a distance of one hundred (100) feet from the property.

16 (h) Lot No. 1, Block No. 8, Tract No. 1113, GOV/FEMA  
17 Emergency Housing Project, Government of Guam Subdivision,  
18 municipality of *Dededo*, containing an area of six hundred twenty-four  
19 (624) $\pm$  square meters or six thousand seven hundred nineteen (6,719) $\pm$   
20 square feet, as shown on a map prepared by Land Management, No. I4-  
21 94T561, L.M. Check No. 214FY94, Subdivision Survey Map of Tract 1113,  
22 formerly Lot No. 10125-11-1, recorded under Document No. 503994,  
23 Certificates of Title No. 35085, Estate No. 22092 together with a three (3)  
24 bedroom structure. Water and power (electricity) and sewer are immediately  
25 available or within a distance of one hundred (100) feet from the property.

26 (i) Lot No. 2, Block No. 8, Tract No. 1113, GOV/FEMA  
27 Emergency Housing Project, Government of Guam Subdivision,

1 the opportunity to fulfill their contractual agreement. Heirs of the persons  
2 who were awarded the lots should be allowed to fulfill their contractual  
3 agreement if they meet the eligibility requirements. If there is more than one  
4 (1) heir, the lot or lots *shall* be drawn by lottery if not in probate or in a will  
5 or by quitclaim of all other heirs.

6 (2) If lots are still available after going through the process as  
7 outlined in (1) above, said lots *shall* be made available to the eligible  
8 *Chamorro* Land Trust Commission applicants on the waiting list starting  
9 from the first in line.

10 (3) When the Guam Housing Corporation has exhausted all efforts  
11 in (1) and (2) above, the Guam Housing Corporation will announce the  
12 availability of lots and receive applications for interested persons who meet  
13 the eligibility requirements of the original program. If the Guam Housing  
14 Corporation receives more applications than the number of lots available, a  
15 lottery will be used to award the lots.

*MINA' TRENTAI UNU NA LIHESLATURAN GUÅHAN*  
2012 (SECOND) Regular Session

2012 JAN 23 11:12:45  
MWW

Bill No. 411-31 (Cov)

Introduced by:

T. R Muña Barnes

**AN ACT TO AUTHORIZE *I MAGA'LAHEN GUÅHAN* TO TRANSFER ABANDONED PROPERTIES LOCATED WITHIN TRACT NUMBER 1113 ALSO KNOWN AS THE SAGAN LINAHYAN SUBDIVISION, FROM THE *DIPATTAMENTON MINANEHAN TÅNO'* (DEPARTMENT OF LAND MANAGEMENT) TO THE GUAM HOUSING CORPORATION FOR THE PURPOSE OF AFFORDABLE HOUSING**

**BE IT ENACTED BY THE PEOPLE OF GUAM:**

**Section 1. Legislative Findings.** *I Liheslaturan Guåhan* finds that Public Laws 21-60, 21-72, and 21-146, gave the Department of Land Management the authority to transfer certain property belonging to the Government of Guam to qualified individuals for residential use. Pursuant to this authority, the Government entered into various conditional contracts to deed residential property. By the terms of these contracts, if the qualifying individuals paid to the Government the amount of \$2500.00, amortized over a ten year period, they would receive a deed to the property in fee simple.

*I Liheslaturan Guåhan* further finds that while the program is in many respects successful, it is also true that some qualifying individuals were unable to meet their obligations under the contracts. Accordingly, as a result of default, at least ten of these conditional contracts to deed were terminated.

1 Municipality of Dededo, containing an area 564± square meters or  
2 6,068± square feet, as shown on a map prepared by Land  
3 Management, No. I4-94T561, L.M. Check No. 214FY94 Subdivision  
4 Survey Map of Tract 1113, formerly Lot No. 10125-11-1, recorded  
5 under Document No. 503994, Certificates of Title No. 35085, Estate  
6 No. 22092 together with a three (3) bedroom structure. Water and  
7 power (electricity) and sewer are immediately available or within a  
8 distance of 100 feet from the property.

9 (c) Lot No. 14, Block No. 12, Tract No. 1113, GOV/FEMA  
10 Emergency Housing Project, Government of Guam Subdivision,  
11 Municipality of Dededo, containing an area 564± square meters or  
12 6,068± square feet , as shown on a map prepared by Land  
13 Management, No. I4-94T561, L.M. Check No. 214FY94, Subdivision  
14 Survey Map of tract 1113, formerly lot No. 10125-11-1, recorded  
15 under Document No. 503994, Certificates of Title No. 35085, Estate  
16 No. 22092 together with a three (3) bedroom structure. Water and  
17 power (electricity) and sewer are immediately available or within a  
18 distance of 100 feet from the property.

19 (d) Lot No. 17, Block No. 12, Tract No. 1113, GOV/FEMA  
20 Emergency Housing Project, Government of Guam Subdivision,  
21 Municipality of Dededo, containing an area 564± square meters or  
22 6,068± square feet, as shown on a map prepared by Land  
23 Management, No. I4-94T561, L.M. Check No. 214FY94, Subdivision  
24 Survey Map of Tract 1113, formerly Lot No. 10125-11-1, recorded  
25 under Document No. 503994, Certificates of Title No. 35085, Estate  
26 No. 22092 together with a one (1) bedroom structure. Water and

1 Survey Map of Tract 1113, formerly Lot No. 10125-11-1, recorded  
2 under Document No. 503994, Certificates of Title No. 35085, Estate  
3 No. 22092 together with a one (1) bedroom structure. Water and  
4 power (electricity) and sewer are immediately available or within a  
5 distance of 100 feet from the property.

6 (h) Lot No. 1, Block No. 8, Tract No. 1113, GOV/FEMA Emergency  
7 Housing Project, Government of Guam Subdivision, Municipality of  
8 Dededo, containing an area  $624\pm$  square meters or  $6,719\pm$  square feet,  
9 as shown on a map prepared by Land Management, No. I4-94T561,  
10 L.M. Check No. 214FY94, Subdivision Survey Map of Tract 1113,  
11 formerly Lot No. 10125-11-1, recorded under Document No. 503994,  
12 Certificates of Title No. 35085, Estate No. 22092 together with a three  
13 (3) bedroom structure. Water and power (electricity) and sewer are  
14 immediately available or within a distance of 100 feet from the  
15 property.

16 (i) Lot No. 2, Block No. 8, Tract No. 1113, GOV/FEMA Emergency  
17 Housing Project, Government of Guam Subdivision, Municipality of  
18 Dededo, containing an area  $552\pm$  square meters or  $5,947\pm$  square feet,  
19 as shown on a map prepared by Land Management, No. I4-94T561,  
20 L.M. Check No. 214FY94, Subdivision Survey Map of Tract 1113,  
21 formerly Lot No. 10125-11-1, recorded under Document No. 503994,  
22 Certificates of Title No. 35085, Estate No. 22092 together with a one  
23 (1) bedroom structure. Water and power (electricity) and sewer are  
24 immediately available or within a distance of 100 feet from the  
25 property.

26 (j) Lot No. 7, Block No. 9, Tract No. 1113, GOV/FEMA Emergency  
27 Housing Project, Government of Guam Subdivision, Municipality of



# FISHER & ASSOCIATES

ATTORNEYS AT LAW

18 May 2012

GUAM HOUSING  
CORPORATION

MAY 18 2012  
RECEIVED

Mr. Martin Benavente  
President  
Guam Housing Corporation  
ITC Building, Suite 535  
590 South Marine Corps Dr.  
Tamuning, Guam 96911

Dear Mr. Benavente,

The Guam Housing Corporation has asked me to draft a conveyance of certain property now in possession of the Department of Land Management (DLM) and located in the Sagan Linahyan subdivision to the Guam Housing Corporation (GHC).

As you know the Guam Legislature recently passed Bill 411-31 which became Public Law 31-209. This law allows the transfer of property but contains certain conditions precedent. Prior to transfer of the named parcels from DLM to GHC, the Corporation must publish in a newspaper the names of the defaulting individuals and inform them that they may perform their duties under the original conditional contract to deed. *See PL 31-209, Section 4, paragraph (1).*<sup>1</sup> The law is silent as to how the performance is to be done, whether by a new contract (the original contracts are terminated as a result of default) or under the original contract. If under the original, I recommend that the contract terms be accelerated with all payment due immediately. This same section accords rights to heirs where the original party has died. In that case heirs are allowed to perform. Where there is more than one heir, as in the case of a surviving spouse and child, and where decedent died without a will, lots are to be drawn to determine who will take. Note that this provision violates Guam's laws of intestate succession.

Where neither the original party nor an heir takes under the contract, Section 4, paragraph 2 of the Public Law requires the Corporation to make the property available to Chamorro Land Trust applicants. As you know, the Chamorro Land Trust does not convey property in fee, rather it conveys leaseholds. I believe the intent of the section though is to establish a priority among those who may take rather than the type of estate conveyed. Accordingly, after the Corporation has determined that neither the original party to the contract nor heirs will perform the original obligations, the lots are made available to the Land Trust applicants.

When these conditions have been met, the Corporation will announce availability of the remaining lots and receive applications from interested individuals. When the Corporation identifies an eligible transferee, the Corporation may then take possession of the remaining lots. It is at this point the DLM conveys to GHC. Prior

---

<sup>1</sup> This act will require sensitivity to the original party's privacy. A person may not wish to be identified as a recipient of the property, nor as one who has breached the original contract.

to the conveyance, the Corporation is essentially and agent of DLM and acts to convey the property from DLM to the individuals, i.e. the property is not yet in GHC's possession.

As it is determined that no person, heir, or Land Trust applicant will take the property, DLM will convey the property to GHC by grant deed. Thereafter GHC will convey to the recipient. Then, as the Corporation identifies the property and the grantors and grantees, we will create the conveyances.

Sincerely,

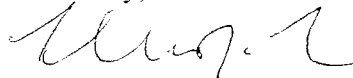

Thomas J. Fisher  
Attorney, Guam Housing Corporation

cc: Mr. Caesar Villanueva



**DIPATTAMENTON MINANEHAN TANO'**  
 (Department of Land Management)  
**GUBETNAMENTON GUAHAN**  
 (Government of Guam)



Street Address:  
 590 S. Marine Corps Drive  
 Suite 733 ITC Building  
 Tamuning, GU 96913

EDDIE BAZA CALVO  
 Governor

MONTE MAFNAS  
 Acting Director

RAY TENORIO  
 Lieutenant Governor

October 28, 2011

Memorandum

To: President, Guam Housing Corporation  
 From: Acting Director, Department of Land Management  
 Subject: Abandon Homes within the Sagan Lintahyan Subdivision

Mailing Address:  
 P.O. Box 2950  
 Hagåtña, GU 96932

*Buenas yan Hafa Adai!*

Website:  
<http://dlm.guam.gov>

Our department has recognized the need for affordable housing on Guam. In response to your agencies ability to fund the rehabilitation of abandon homes, we have identified ten (10) parcels with homes located in the FEMA/GovGuam Subdivision, Municipality of Dededo, more particularly described as the Sagan Lintahyan Subdivision, authorized under the Land for the Landless Program.

E-mail Address:  
[dlmdir@dlm.guam.gov](mailto:dlmdir@dlm.guam.gov)

In recent months there have been several discussions to enact legislation for the transfer of these parcels which in turn would provide opportunities for qualified CLTC applicants to obtain the homes through a lease to own program. With preference being given to CLTC Applicants, provided they meet the income requirements established and can demonstrate the repayment ability.

Telephone:  
 671-649-LAND (5263)

Attached is the listing of government parcels that have been identified and is hereby made available for future transfer to your agency, subject to legislative approval

Facsimile:  
 671-649-5383

For more information, please contact me at 649-5263 Ext 650.

Senseramente,

  
 Monte Mafnas

Attachment

**GUAM HOUSING CORP.**

REC'D:                       
 10/28/11

Island of Guam, Government of Guam  
Department of Land Management Office of the Recorder

File for Record is Instrument No. 828203

On the Year 11 Month 10 Day 24 Time 8:04  
DE-OFFICIO

Recording Fee \_\_\_\_\_ Receipt No. \_\_\_\_\_

Deputy Recorder Lisa O. Manggar

(SPACE ABOVE THIS LINE FOR RECORDER'S USE)

**TERMINATION OF CONDITIONAL CONTRACT TO DEED**

WHEREAS, the GOVERNMENT OF GUAM, SELLER, and **Betty Mantanona**, PURCHASER, entered into a Conditional Contract to Deed on the 26<sup>TH</sup> day of August 1994, to purchase the following described property: **1845**

Lot No.21, Block No.12, Tract No. 1113, GOV/FEMA Emergency Housing Project, Government of Guam Subdivision, Municipality of Dededo, containing an area 564± square meters or 6,068± square feet, as shown on map prepared by Land Management No. I4-94T561, L.M. Check No. 214FY94, Subdivision Survey Map of Tract 1113, formerly Lot No. 10125-11-1, recorded under Document No. 503994, Certificates of Title No. 35085, Estate No. 22092 together with a One (1) bedroom structure. Water and power (electricity) and sewer are immediately available or within a distance of 100 feet from the property.

WHEREAS, the PURCHASER agreed to purchase the property for Two Thousand Five Hundred Dollars (\$2,500.00) on August 26, 1994. The PURCHASER paid the ten percent (10%) down payment of the agreed purchase price. The remaining balance to be paid annually starting on March 02, 1995 and expires on March 02, 2004.

WHEREAS, the sum of TWO HUNDRED FIFTY DOLLARS, (\$250.00) has been applied to the principal due under the Conditional Contract to Deed, and shall be retained by the Government as liquidated damages.

In accordance with Section 4 of the Conditional Contract to Deed attached as EXHIBIT "A", pursuant to Public Law 21-60, 21-72 & 21-146, I, **Monte Mafnas**, the Acting Director of Land Management exercises the right to terminate the right to your Contract recorded under Document No. 523802.

GOVERNMENT OF GUAM:

*Monte Mafnas*

**Monte Mafnas**, Acting Director  
Department of Land Management

Date: 10-21-11

ACKNOWLEDGEMENT

CITY OF TAMUNING ) SS

On this 21st day of October, 2011, before me the undersigned notary, personally appeared **Monte Mafnas**, Acting Director, Department of Land Management, known to me to be the person whose name is subscribed to the within instrument and acknowledged to me that he executed the same.

IN WITNESS WHEREOF, I have hereunto affixed my name and official seal in Tamuning, Guam the day and year first above written.

*Teresita A.C. Toves*

NOTARY

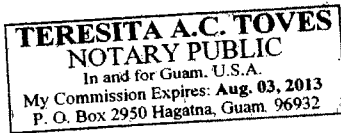

CONDITIONAL CONTRACT TO DEED

THIS AGREEMENT, entered into this 26th day of August, 19 94, by the GOVERNMENT OF GUAM, hereinafter known as the GOVERNMENT and \_\_\_\_\_ Single person as her sole and separate property; S/S No. \_\_\_\_\_ P.O. Box 10434, Sinajana, Guam 96926, resident of Guam, Municipality of DEDEDO, hereinafter known as the PURCHASER.

WITNESSETH:

WHEREAS, the GOVERNMENT is the owner of certain property located in the Municipality of DEDEDO, Guam, hereinafter known as the premises, more particularly described as follows:

Lot No. 21, Block No. 12, Tract No. 1113, Gov/Fema Emergency Housing Project, Government of Guam Subdivision, Municipality of Dededo containing an area of 564± Square Meters or 6,068± Square Feet as shown on MAP L.M. Check No. 214FY94, Drawing No. I4-94T561, Recorded under Document No. 503994, together with a one (1) bedroom structure. Water, power (Electricity), and sewer are immediately available or within a distance of 100 feet from the property.

WHEREAS, the PURCHASER has fulfilled the statutory and regulatory prerequisites to the acquisition of and from the GOVERNMENT OF GUAM.

NOW THEREFORE, the PURCHASER and the GOVERNMENT agrees as follows:

Interest payment is an additional amount that is due at same time ~~as~~ the principal amount.

This amount will vary depending upon when payment is made.

1. That the total purchase price is TWO THOUSAND FIVE HUNDRED DOLLARS (\$2,500.00) payable as follows:

The down payment of TWO HUNDRED FIFTY DOLLARS (\$250.00) which constitutes Ten Percent (10%) of the agreed purchase price, receipt of which is hereby acknowledged; and the balance of the principal as follows:

On 3/02/95	TWO HUNDRED TWENTY-FIVE DOLLARS	(\$225.00)
On 3/02/96	TWO HUNDRED TWENTY-FIVE DOLLARS	(\$225.00)
On 3/02/97	TWO HUNDRED TWENTY-FIVE DOLLARS	(\$225.00)
On 3/02/98	TWO HUNDRED TWENTY-FIVE DOLLARS	(\$225.00)
On 3/02/99	TWO HUNDRED TWENTY-FIVE DOLLARS	(\$225.00)
On 3/02/2000	TWO HUNDRED TWENTY-FIVE DOLLARS	(\$225.00)
On 3/02/2001	TWO HUNDRED TWENTY-FIVE DOLLARS	(\$225.00)
On 3/02/2002	TWO HUNDRED TWENTY-FIVE DOLLARS	(\$225.00)
On 3/02/2003	TWO HUNDRED TWENTY-FIVE DOLLARS	(\$225.00)
On 3/02/2004	TWO HUNDRED TWENTY-FIVE DOLLARS	(\$225.00)

## CONDITIONAL CONTRACT TO DEED -

5. The PURCHASER must use the premises for residential purposes only. PURCHASER must, within three (3) years of the availability of water and power by the government for immediate residential usage construct a residential building on the premises, in conformity with the residential construction requirements of the Department of Public Works in effect at the time of construction. The residence constructed on the premises must be regularly occupied by members of the immediate family PURCHASER and no others.

6. The title to the premises shall remain in the GOVERNMENT until the completion of the above conditions. Upon such completion, the GOVERNMENT agrees to deliver to the PURCHASER fee simple title to the premises with the following reservations:

a. All rights title and interest in, and to adjoining streets and alleyways shall be specifically reserved to the GOVERNMENT.

b. The Government will reserve for itself easements and right-of-way, in perpetuity, in, under, through, over and across the above described parcel of land, except where the residence is actually located, for the purpose at any time, of constructing, placing, maintaining, repairing and operating sewage, drainage, and utility lines of any nature whatsoever, together with all rights and privileges, including the rights of ingress to and from the parcel of land inherent in the use and exercise of such easements and rights-of-way, and including the right to make reasonable changes and alterations in connection with the locations, sizes or types of said sewage, drainage, or utility lines as the GOVERNMENT may from time to time, in its sole discretion, deem appropriate.

Conditional Contract to Deed -

ACKNOWLEDGMENT

TERRITORY OF GUAM)  
  )SS  
CITY OF AGANA                  )

On this 10TH day of Aug., 19 94, before me, the undersigned notary, personally appeared F. L.G. CASTRO, Director of Land Management, the person whose name is signed on the preceding or attached document, and acknowledged to me that he signed it voluntarily for its stated purpose.

IN WITNESS WHEREOF, I have hereunto affixed my name and official seal in Agana, Guam, the day and year first above written.

*Steven P. Luna*  
\_\_\_\_\_  
STEVEN P. LUNA  
Notary Public  
In and for the Territory of Guam  
My Commission Expires: 12/17/96

PURCHASER

\_\_\_\_\_  
DATE: 8/13/94

ACKNOWLEDGMENT

TERRITORY OF GUAM)  
  )SS  
CITY OF AGANA                  )

On this 3RD day of August, 19 94, before me the undersigned notary, personally appeared the person whose name is signed on the preceding or attached document, and acknowledged to me that she signed it voluntarily for its stated purpose as eligible purchaser for Lot No. 21, Block No. 12, Tract No. 1113, Gov/Fema Emergency Housing Project, Government of Guam Subdivision, Municipality of Dededo pursuant to Public Laws 21-60, 21-72 and 21-146, as further amended.

IN WITNESS WHEREOF, I have hereunto affixed my name and official seal in Agana, Guam, the day and year first above written.

*Steven P. Luna*  
\_\_\_\_\_  
STEVEN P. LUNA  
Notary Public  
In and for the Territory of Guam  
My Commission Expires: 12/17/94



ID	Task Name	Duration	Start	Finish	Pred,Resource Names	2nd Quarter			3rd Quarter		
						Middle	End	ginni Middle	End	ginni Middle	End
1	GHC -10 homes	123 days?	Mon 2/20/12	Wed 8/8/12							
2	scope of repair work	16 days	Mon 2/20/12	Mon 3/4/12							
3	environmental review	4 days	Mon 3/5/12	Thu 3/8/12							
4	memo for AG review	1 day?	Thu 3/8/12	Thu 3/8/12							
5	review scope with GHC	5 days?	Tue 3/13/12	Mon 3/19/12							
6	specification	5 days?	Tue 3/20/12	Mon 3/26/12							
7	bid ad	23 days?	Tue 4/17/12	Thu 5/17/12							
8	bid results review with AG	3 days	Fri 5/18/12	Tue 5/22/12							
9	board approval	5 days?	Wed 5/23/12	Tue 5/29/12							
10	notice of intent	10 days?	Wed 5/30/12	Tue 6/12/12							
11	notice to proceed	55 days	Wed 6/13/12	Tue 8/28/12							
12	final inspection	4 days	Mon 8/6/12	Thu 8/9/12							
13											
14											
15	staff housing	123 days?	Mon 3/12/12	Wed 8/29/12							
16	scope of repair work	16 days?	Mon 3/12/12	Mon 4/2/12							
17	environmental review	14 days	Mon 3/12/12	Thu 3/29/12							
18	memo for AG review	1 day?	Mon 3/12/12	Mon 3/12/12							
19	review scope with staff	4 days	Fri 3/30/12	Wed 4/4/12							
20	specification	5 days	Wed 4/4/12	Tue 4/10/12							
21	bid ad	23 days?	Tue 4/24/12	Thu 5/24/12							
22	bid results review with AG	4 days	Fri 5/25/12	Wed 5/30/12							
23	board approval	9 days?	Mon 6/4/12	Thu 6/14/12							
24	notice of intent	10 days	Fri 6/15/12	Thu 6/28/12							
25	notice to proceed	55 days	Fri 6/29/12	Thu 9/13/12							
26	final inspection	3 days	Mon 9/10/12	Wed 9/12/12							
27											
28											
29											
30	UPCS insp. of ironwood Glen	10 days?	Mon 4/2/12	Fri 4/13/12							
31											
32	UPS insp. Liheng units	5 days?	Mon 6/11/12	Fri 6/15/12							
33											
34	UPCS insp. Ironwood Estates	10 days	Thu 8/2/12	Wed 8/15/12							

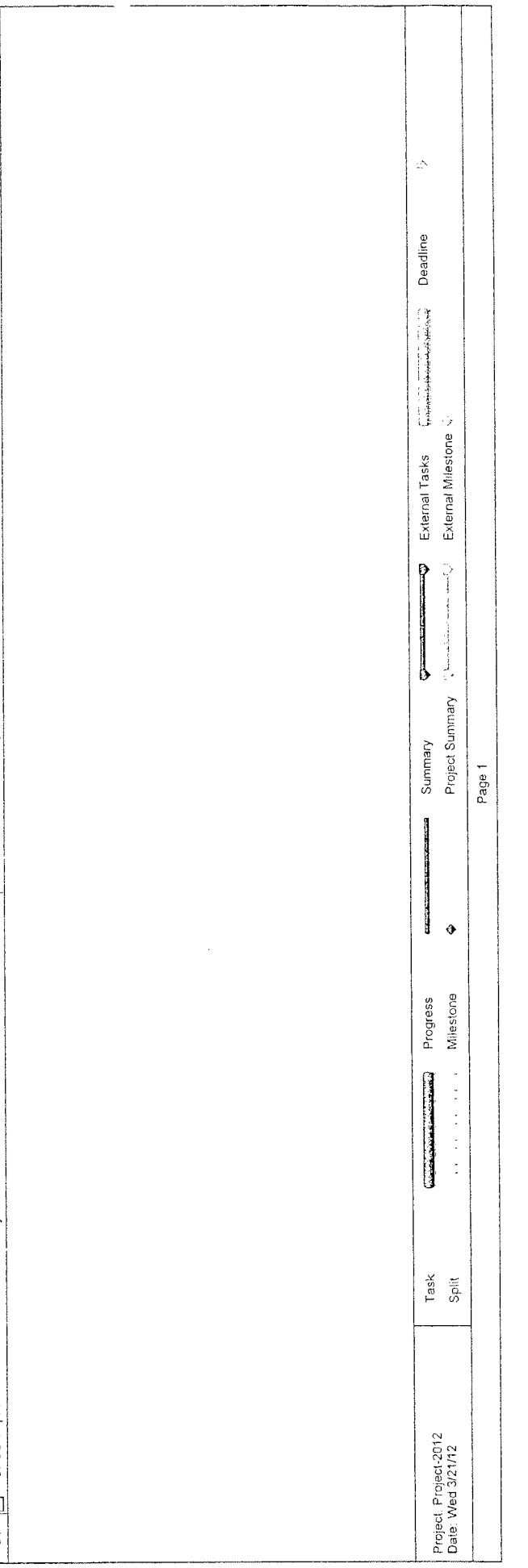

- A12 Provide new water closet, lavatory sink, shower head, toilet paper holder, towel bar, shower curtain rod, medicine cabinet and recessed soap holder.
- A13 Provide threshold type that will prevent water from leaking outside the restroom.

**KITCHEN**

- A14 Existing kitchen counter cabinets and over head cabinets to be removed completely and provide new. New base and overhead cabinets shall be constructed with wood frame (2x2/2x4 wood). All cabinet doors and shelves shall be 3/4" thick plywood and 1/2" thick drawer plywood. New counter cabinet, counter top shall consist with 3-layers of 1/2inch cement board, ceramic tiles, stainless steel sink (6" deep) and all plumbing fixtures needed (level type faucet, supply hose and angle valves...ect.). Provide hinges, door handles and catches, drawer track rollers. All wood frames and plywood shall be termite treated. COUNTER BASE shall be 3" thick concrete w/ #3 rebar @12" O.C. each way. Contractor to submit shop drawings for review and approval prior to start of work.

**OTHERS**

**BLOCK 7 - LOT 14**

- A15 Demolish extension at rear (to-include outside kitchen at storage room). See Floor Plan for location.
- A16 Ballister and concrete curb at front to remain.

**BLOCK 10 - LOT 5**

- A17 Window with concrete infill shall be demolished to its original size. See plan for location
- A17 Demolish tin roof extension at rear to include CMU column.
- A19 CMU partition wall at shower to be demolished.

**BLOCK 12 - LOT 14**

- A20 Demolish existing concrete walkway and replace with new. See plan for location

**BLOCK 9 - LOT 7**

- A21 Wooden over-hang above door opening to be demolished.
- A22 Wall to be infilled with concrete with #4 rebar reinforcement to be embedded with epoxy grout.
- A23 Miscellaneous items of work not indicated but which are necessary to implement the intent of the drawings of which are customarily performed shall be provided by the Contract Bidder as if fully and correctly described in the drawings.

**Notes**

- A24 All woods to be used shall be termite treated.

**PLUMBING WORK**

- P1 Provide water heater with all necessary accesories. See plan for location
- P2 PROVIDE WATERLINE (HOT & COLD) AT ALL AREAS WITH NEW 3/4"DIA. COPPER PIPE LINE. WORK TO INCLUDE FAUCETS, HOSE BIBS, ANGLE VALVES AND OTHER APPERTAINCIES. All material shall be LEAD FREE.
- P3 PROVIDE NEW DRAINAGE AND VENT LINES FOR KITCHEN, BATHROOM AND LAUNDRY
- P4 EXISTING WASTE LINE FLUSH - Contractor shall flush every drainage lines (sink, shower, lavatory, washing machine drain, floor drain, cleanouts, etc.) sections with high pressure system to remove any debris of grease built-up within drainage line.

**ELECTRICAL WORK**

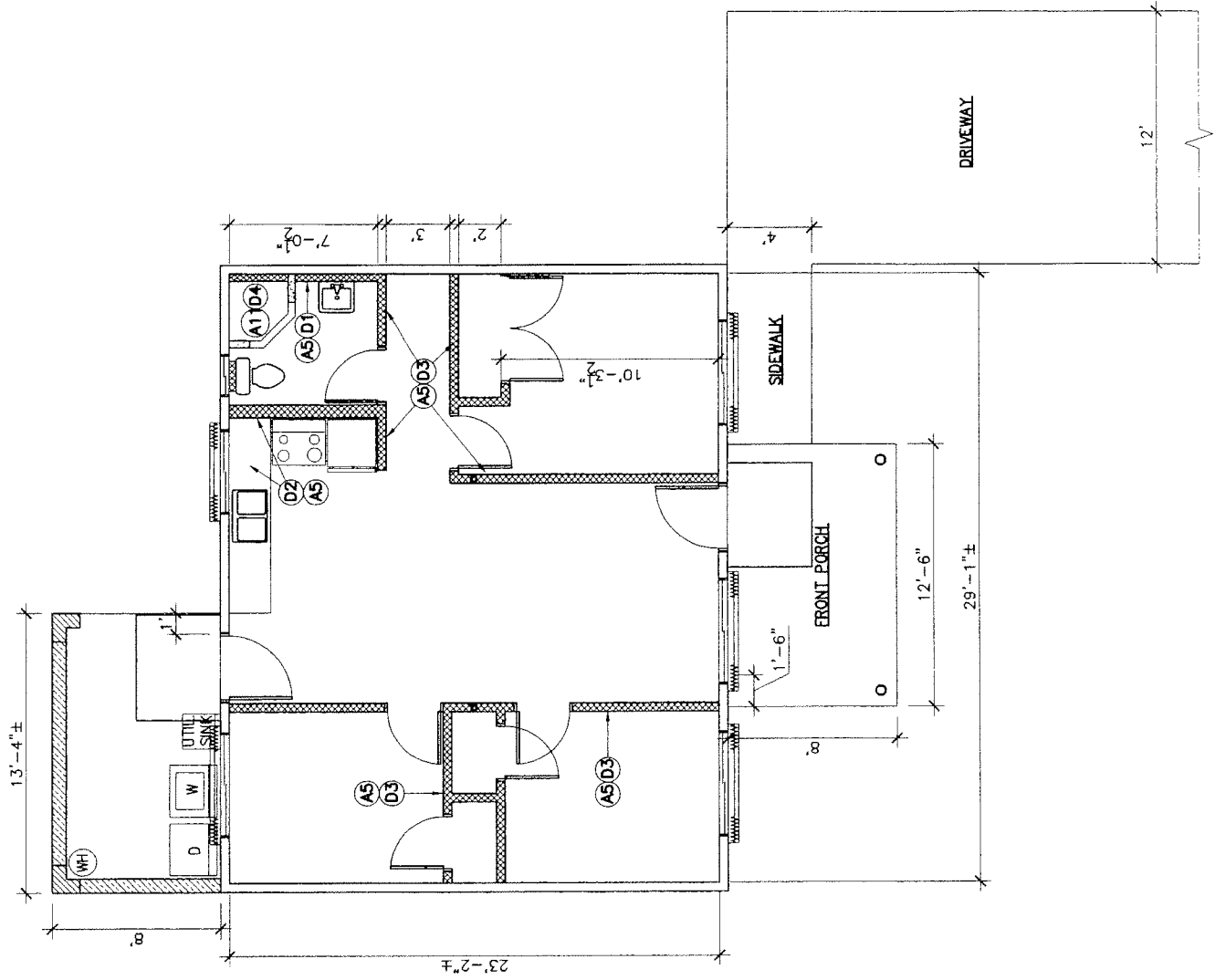

**BLOCK 12 LOT 14**

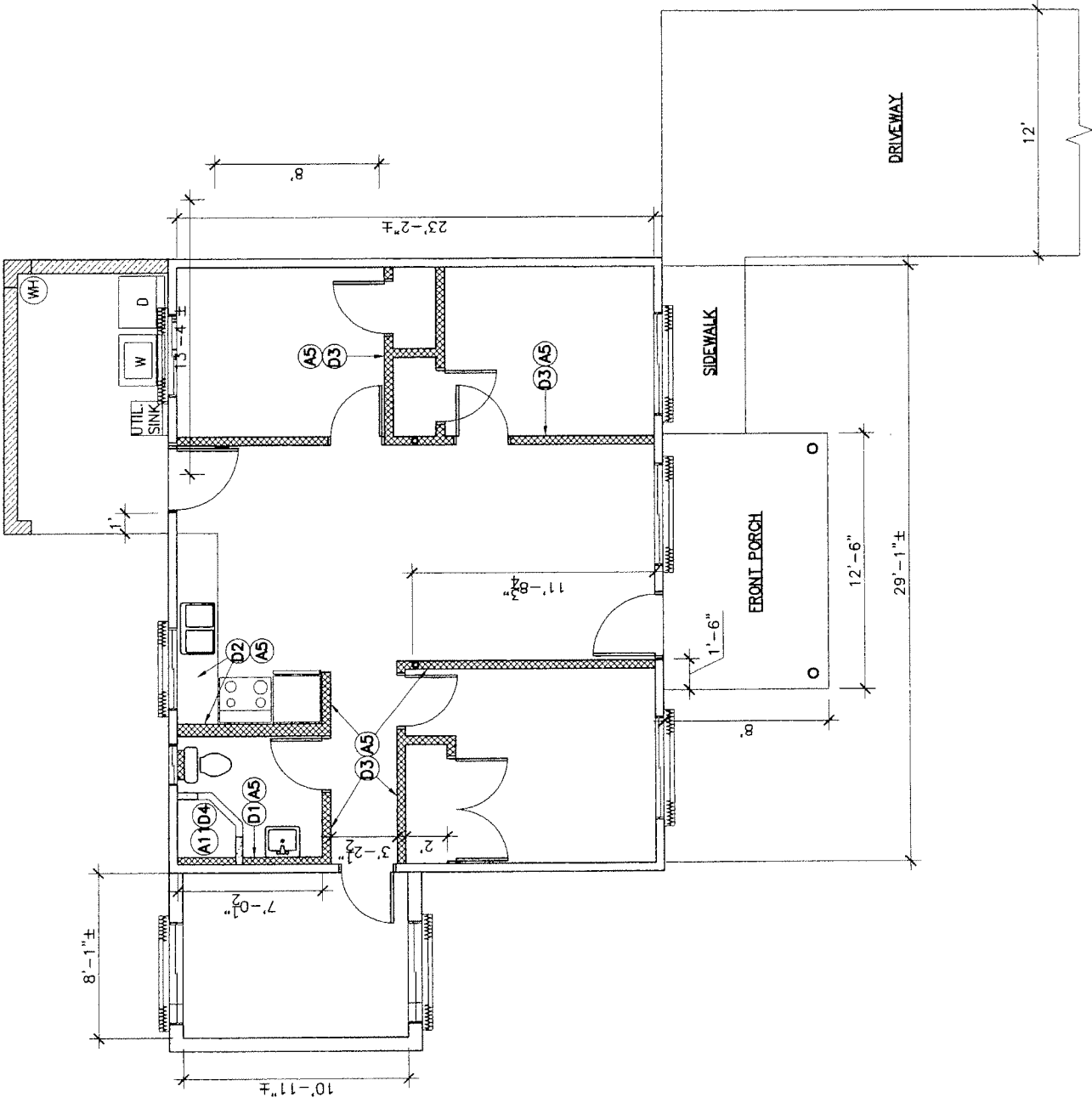

**BLOCK 10 LOT 5**

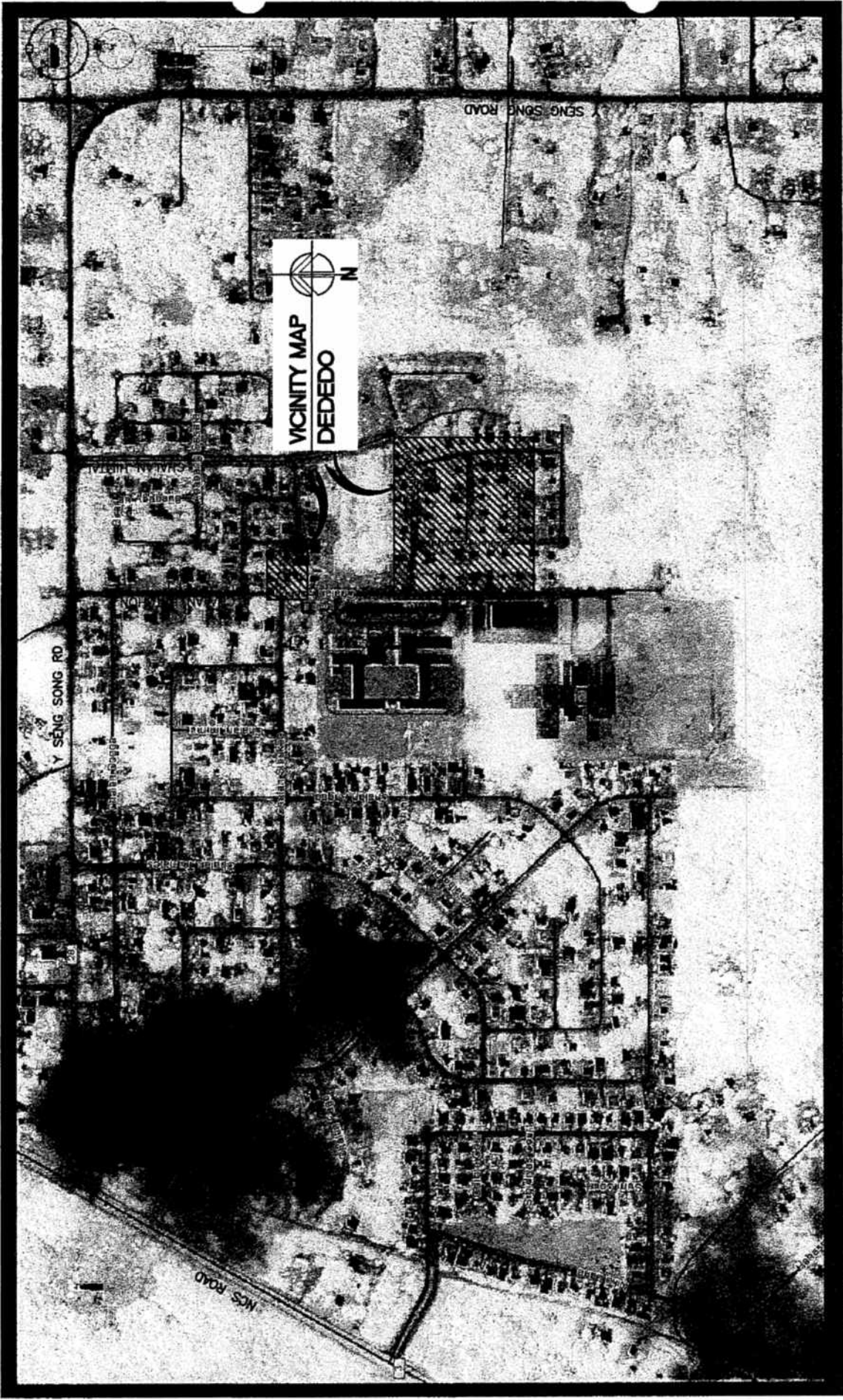

VICINITY MAP  
DEEDED



Y SENG SONG RD

Y SENG SONG RD

NCS ROAD

← TO RT. 3      Y SENG SONG ROAD      TO RT. 1 →

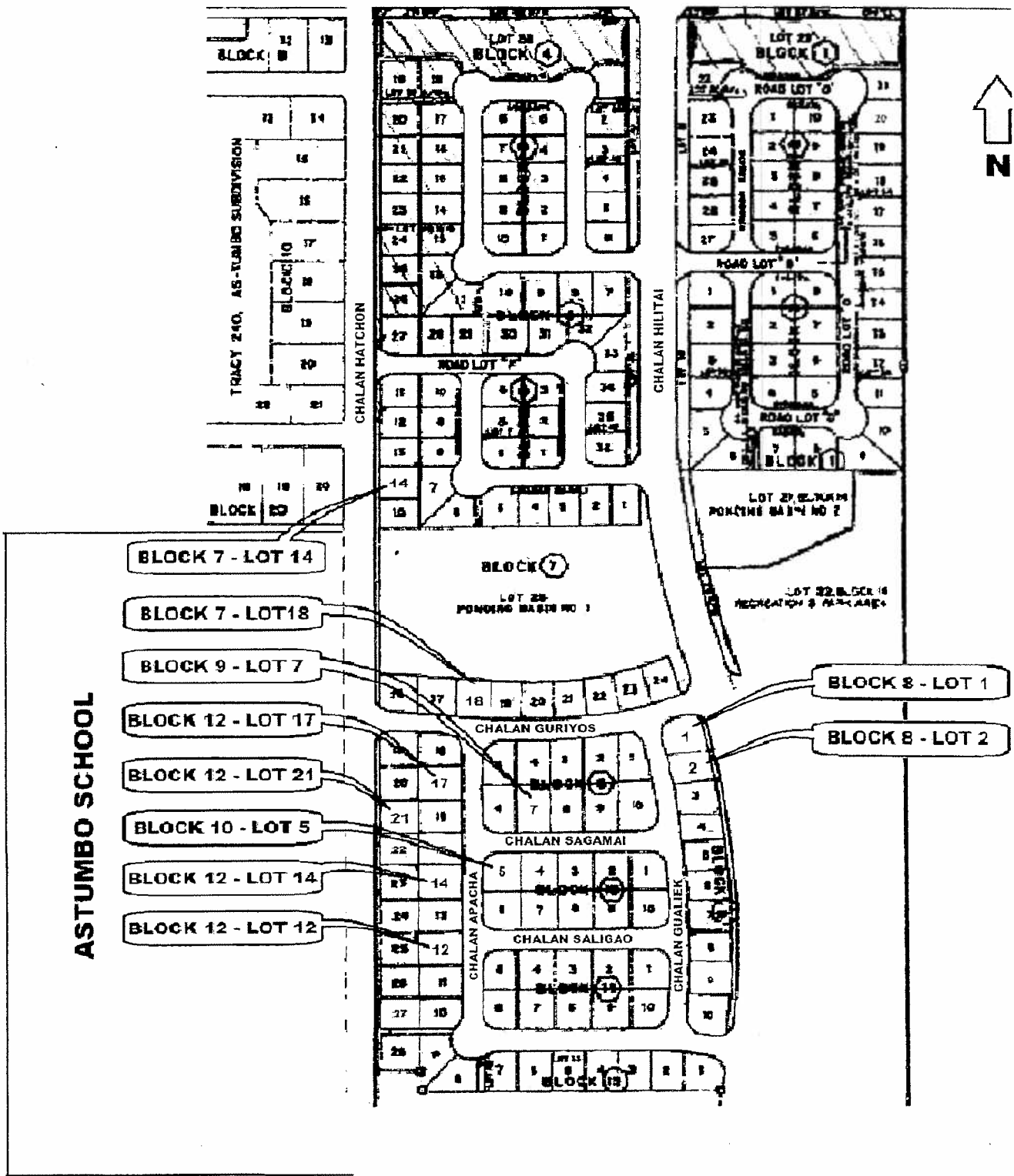

**VICINITY MAP**

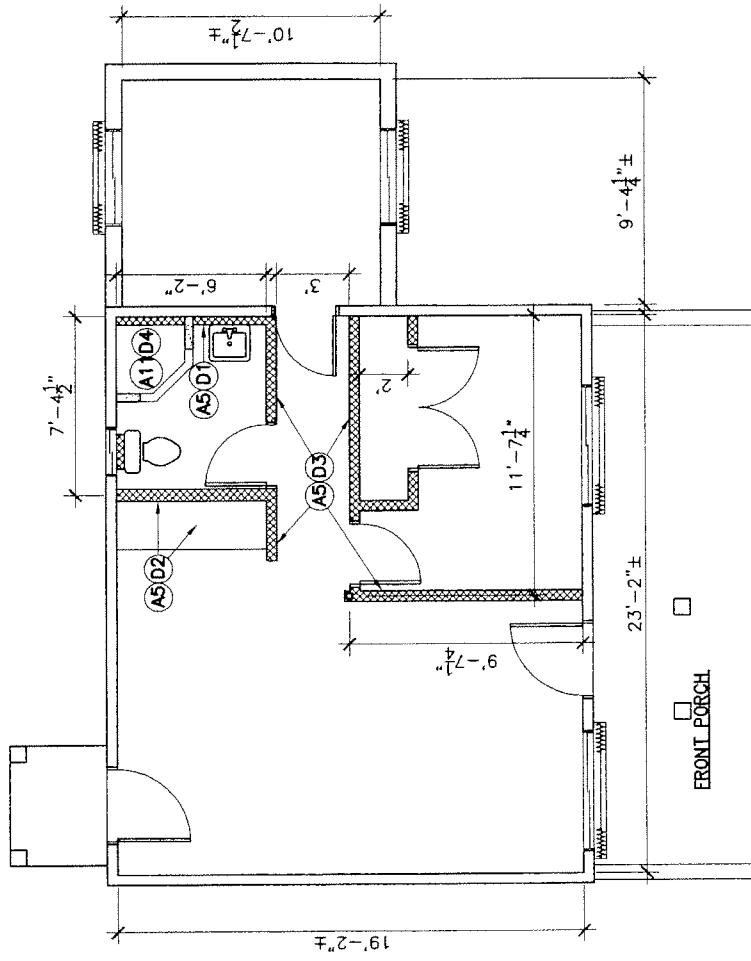

**BLOCK 7 LOT 14**

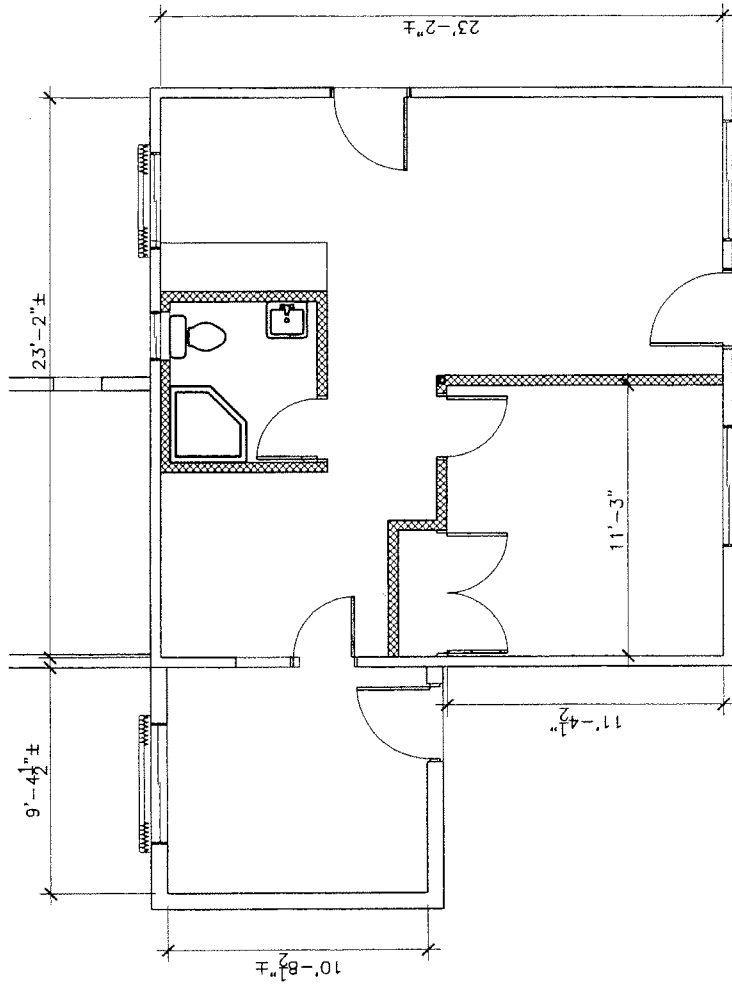

**LOT 7 & BLOCK 9**



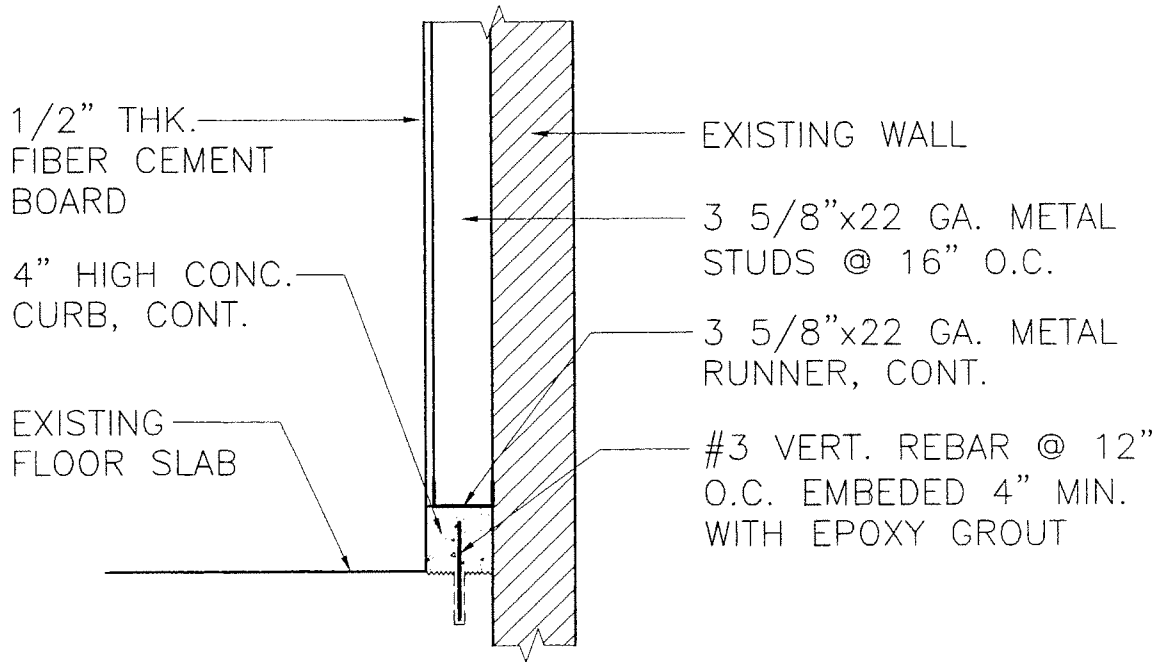

**WALL SECTION DETAIL (D1)**

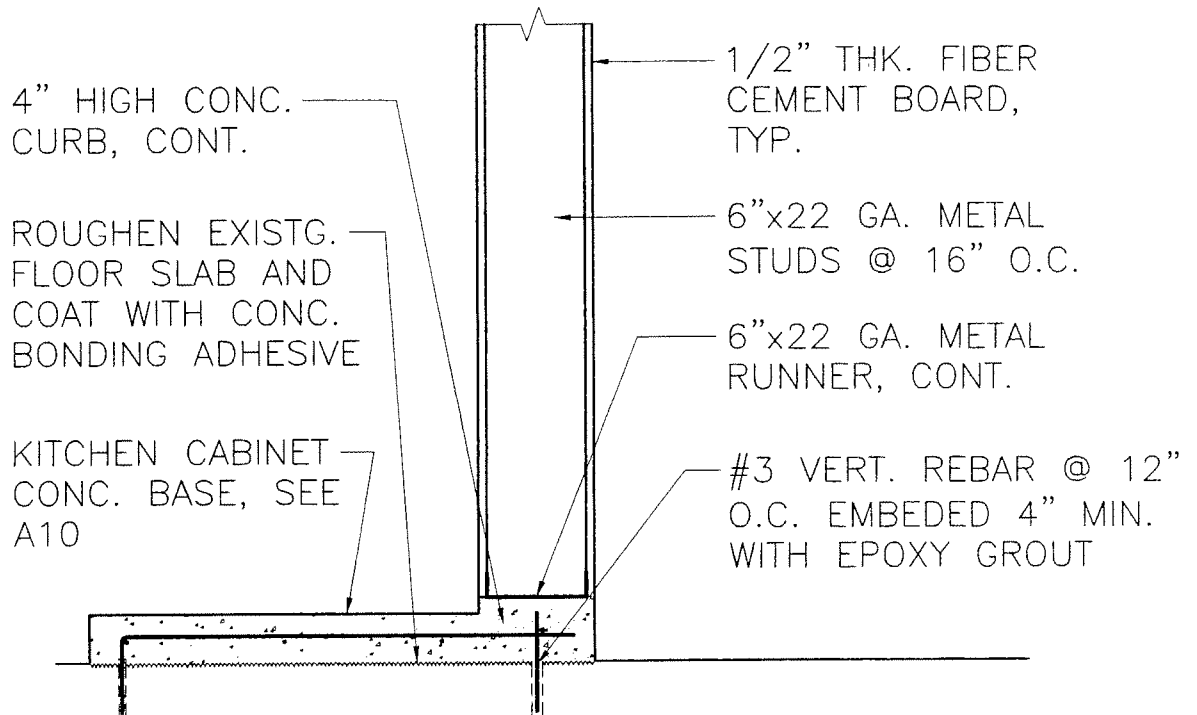

**KITCHEN COUNTER CONC. BASE AND WALL SECTION DETAIL (D2)**

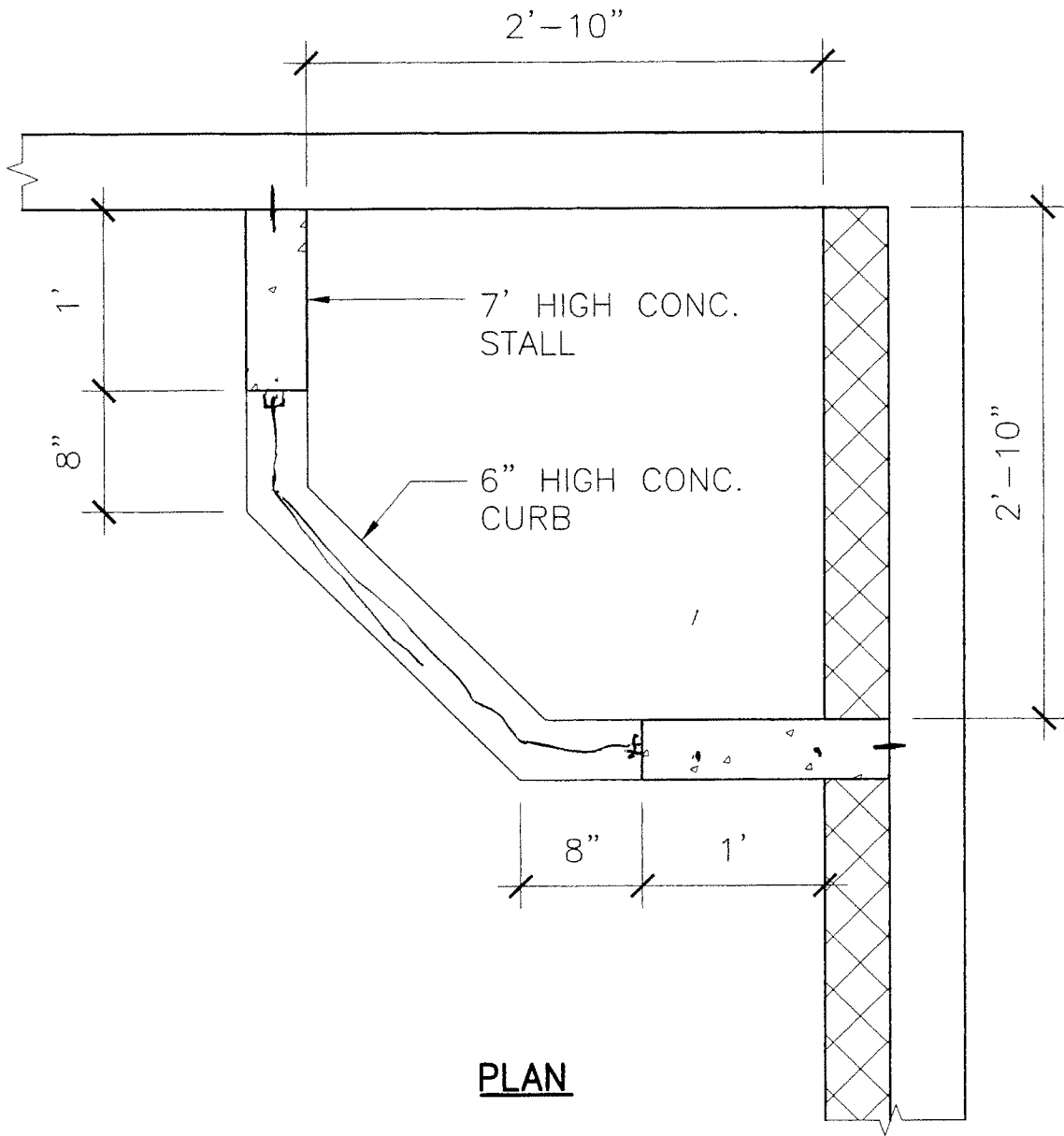

SHOWER STALL (D4)

# ABANDON HOMES PROPOSED TRANSFER TO GVL

TRACT	BLOCK	LOT	FEMA HOME
T1113	B10	L5	3 Bedroom
T1113	B12	L12	3 Bedroom
T1113	B12	L14	3 Bedroom
T1113	B12	L17	1 Bedroom
T1113	B12	L21	1 Bedroom
T1113	B7	L14	1 Bedroom
T1113	B7	L18	1 Bedroom
T1113	B8	L1	1 Bedroom
T1113	B8	L2	1 Bedroom
T1113	B9	L7	1 Bedroom

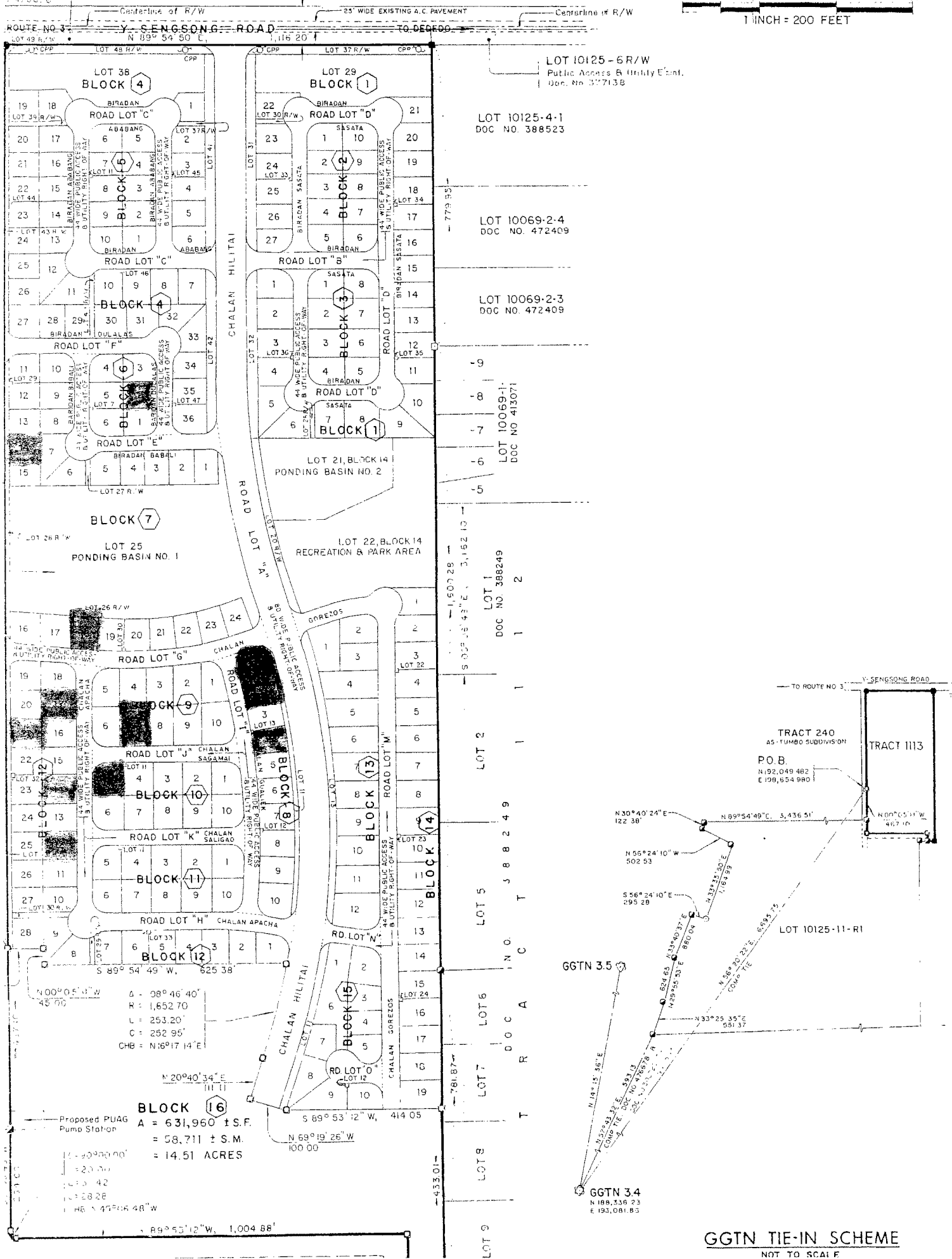

**BLOCK 16**  
 Proposed PUAG Pump Station  
 A = 631,960 ± S.F.  
 = 58,711 ± S.M.  
 = 14.51 ACRES

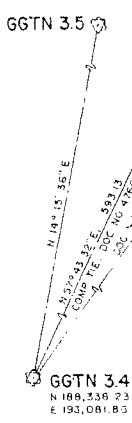

GGTN TIE-IN SCHEME  
NOT TO SCALE

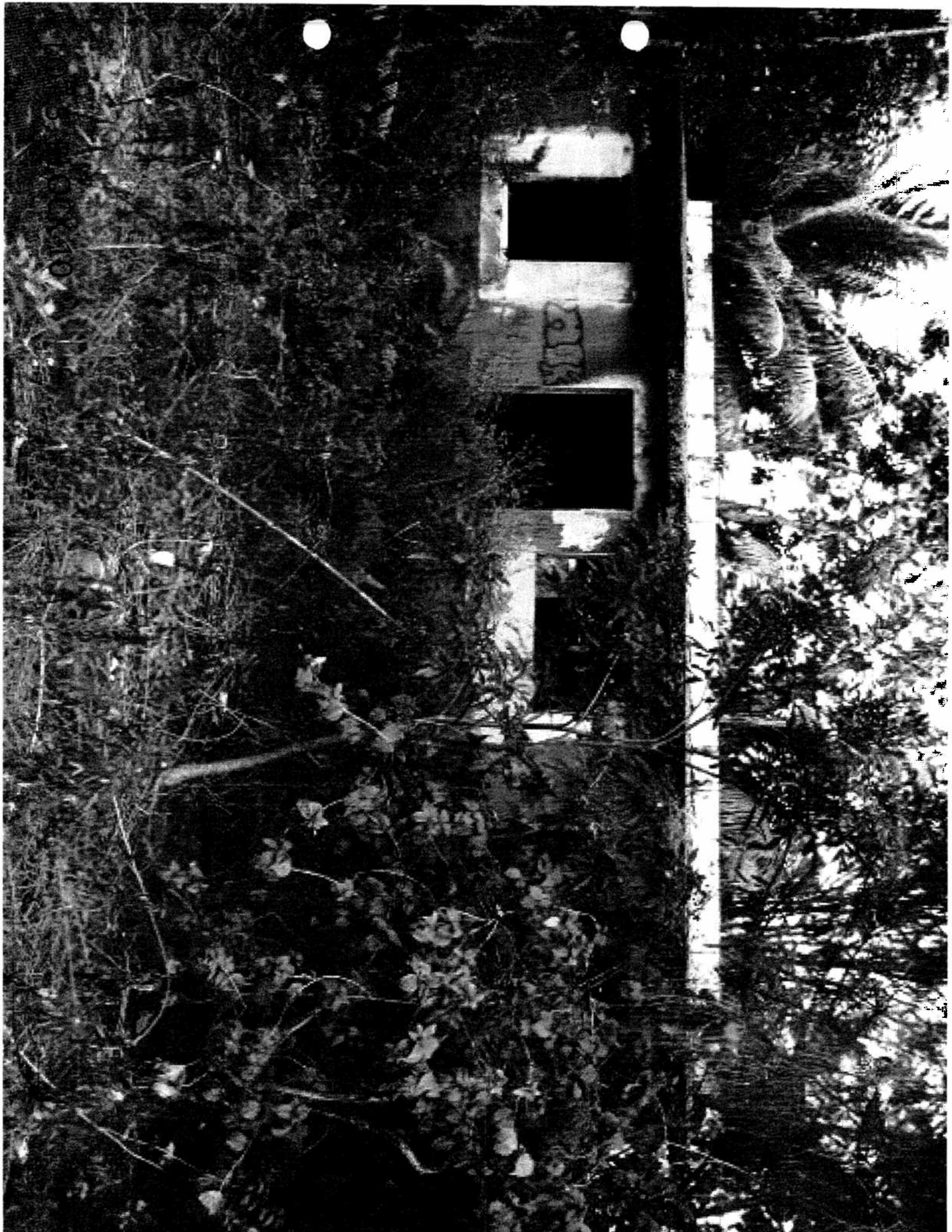





12





LOT 17, BLOCK 12

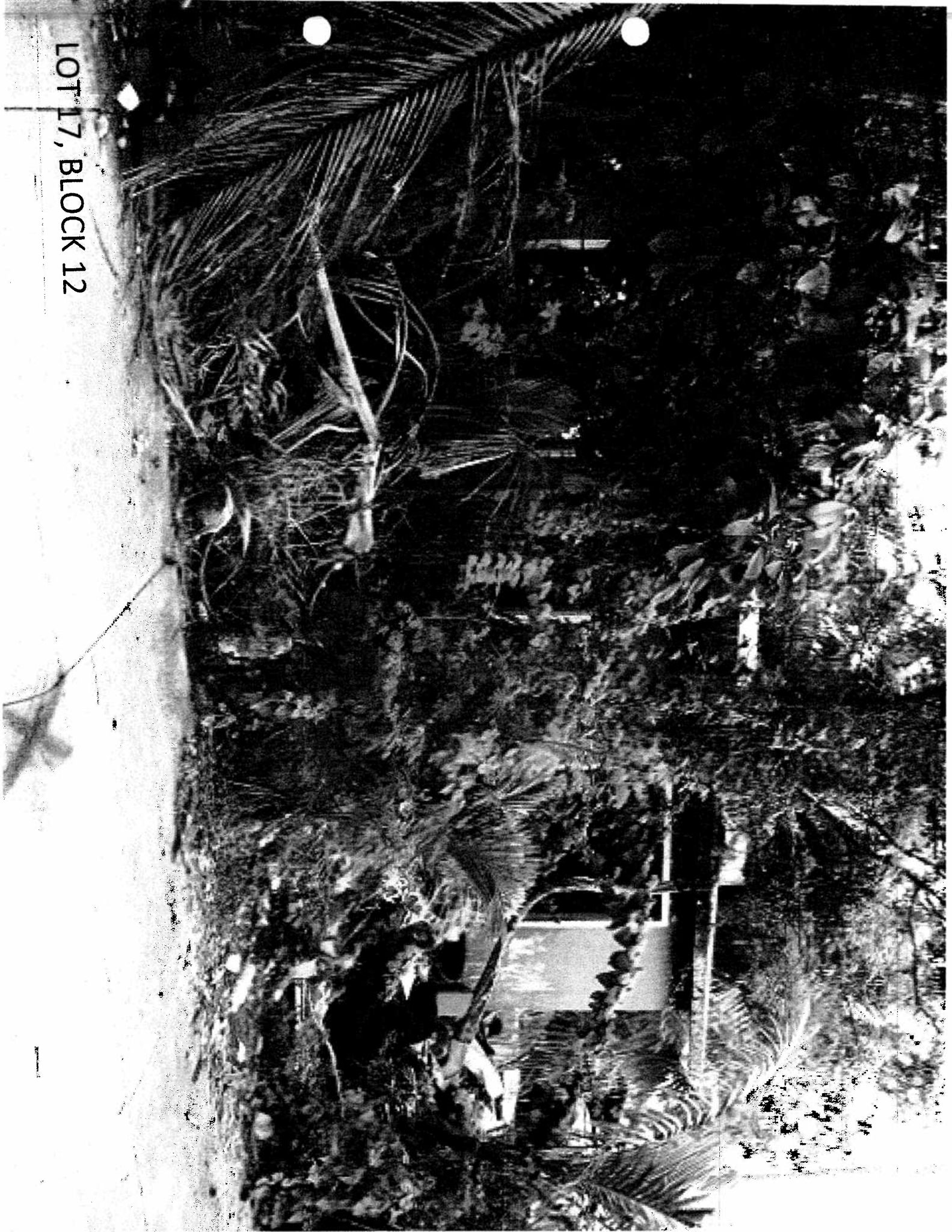





LOT 21, BLOCK 12





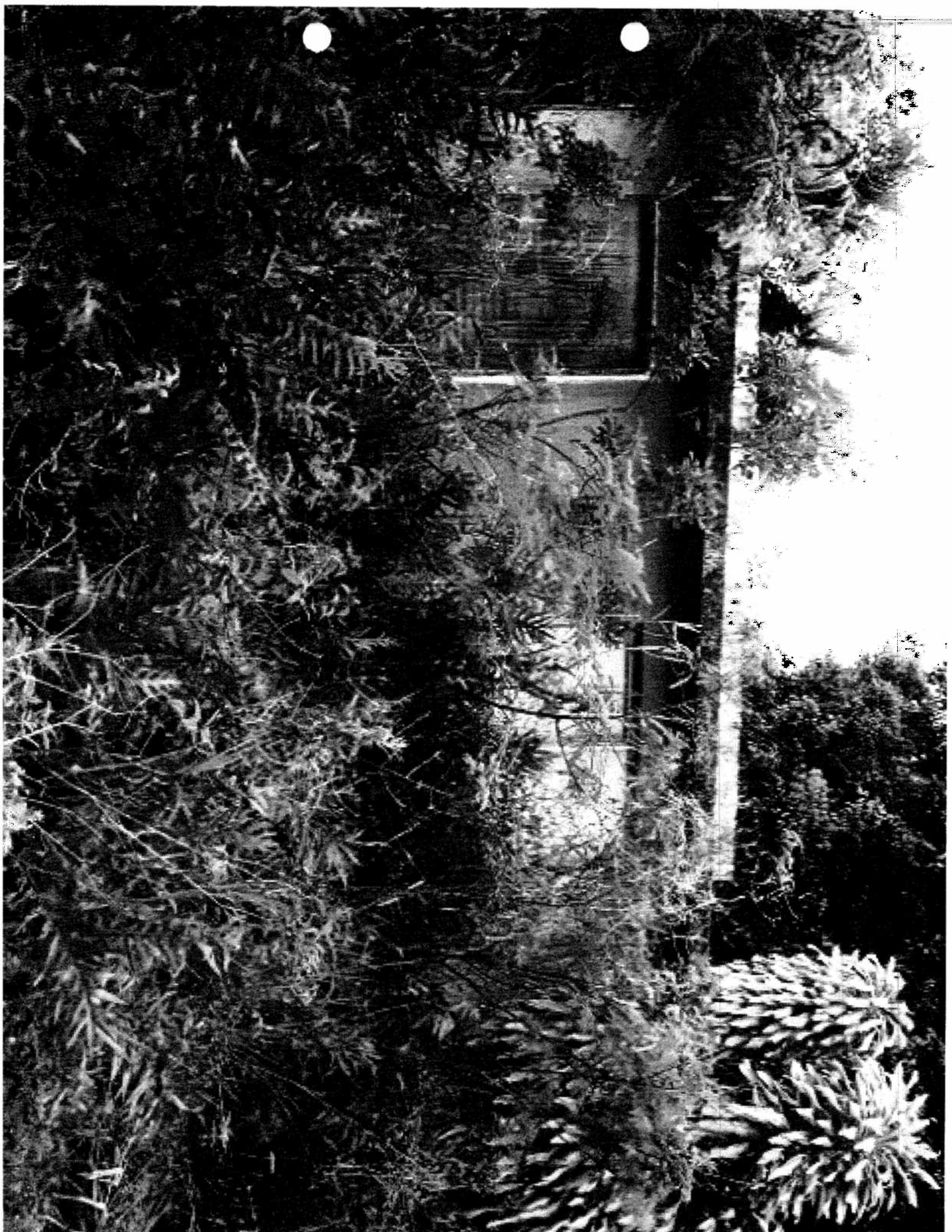

LOT 7, BLOCK 9



**MINA' TRENTAI UNU NA LIHESLATURAN GUÅHAN**  
2012 (SECOND) Regular Session

2012 MAY 18 PM 5:18  
*ERM*

Bill No. 458-31(2012)

Introduced by:

T. R Muña Barnes  
\_\_\_\_\_

**AN ACT TO REPEAL AND RE-ENACT SECTION 4 OF PUBLIC LAW 31-209, RELATIVE TO THE TRANSFER OF PARCELS IN THE SAGAN LINAHYAN SUBDIVISION, DEDEDO, GUAM.**

1           **BE IT ENACTED BY THE PEOPLE OF GUAM:**

2           **Section 1.** Section 4 of Public Law 31-209 is hereby *repealed* and *re-*  
3 *enacted* to read:

4           ~~“Section 4. Transfer of Parcels. Prior to the transfer of parcels~~  
5 ~~within the Sagan Linahyan Subdivision, Dededo, Guam, from the~~  
6 ~~Department of Land Management to the Guam Housing Corporation, the~~  
7 ~~Guam Housing Corporation shall:~~

8                   (1) ~~Publish in a newspaper of general circulation, the names~~  
9                   ~~of the given individuals who had contractual agreements to~~  
10                   ~~purchase the lot and be given the opportunity to fulfill their~~  
11                   ~~contractual agreement. Heirs of the persons who were~~  
12                   ~~awarded the lots should be allowed to fulfill their contractual~~  
13                   ~~agreement if they meet the eligibility requirements. If there~~  
14                   ~~is more than one (1) heir, the lot or lots shall be drawn by~~  
15                   ~~lottery if not in probate or in a will or by quitclaim of all~~  
16                   ~~other heirs.~~

1                   ~~(2) If lots are still available after going through the process~~  
2                   ~~as outlined in (1) above, said lots shall be made available to~~  
3                   ~~the eligible Chamorro Land Trust Commission applicants~~  
4                   ~~on the waiting list starting from the first in line.~~

5                   ~~(3) When the Guam Housing Corporation has exhausted all~~  
6                   ~~efforts in (1) and (2) above, the Guam Housing Corporation~~  
7                   ~~will announce the availability of lots and receive applications~~  
8                   ~~for interested persons who meet the eligibility requirements of~~  
9                   ~~the original program. If the Guam Housing Corporation~~  
10                  ~~receives more applications than the number of lots available, a~~  
11                  ~~lottery will be used to award the lots.~~

12                  **Section 4. Effective Date.** This Act shall be effective upon  
13                  enactment into law.”